

# BOLT ON LIFTING POINT - VLBG LOAD RING



Complies with the machinery directives 2006/42/EC

**4** better lifting



**NB: Please ensure that the safety instructions have been fully read and understood before initial use of the VLBG bolt-on lifting point. Failure to do so may result in serious injuries and/or material damage and eliminates manufacturers warranty.**

## User Instructions - Part 1

### Safety instructions

This safety instruction/declaration of the manufacturer must be kept on file for the lifetime of the product.

**ATTENTION: Please inspect all lifting points prior to use. Damage, incorrect assembly or improper use may result in serious injuries and/or material damage.**

### EC-Declaration of the manufacturer

According to the Machinery Directive 2006/42/EC, annex II B and amendments.

We hereby declare that the design and construction of the equipment detailed within this document, adheres to the appropriate level of health and safety of the corresponding EC regulation.

Any un-authorized modification and/or any incorrect use of the equipment not adhered to within these user instructions waives this declaration invalid.

The equipment must be regularly tested and inspected as per BGR 500. Failure to carry out the recommended maintenance and testing waives this declaration invalid.

### Designation of the equipment:

Type: **VLBG bolt-on lifting point**

Manufacturer's mark:

Drawings (iges, dxf and step), product information and other support material can be downloaded from [www.rud.com.au](http://www.rud.com.au).

<b>EC-Declaration of conformity</b>	
<small>According to the EC-Machinery Directive 2006/42/EC, annex II A and amendments</small>	
Manufacturer:	<b>RUD Ketten Rieger &amp; Dietz GmbH u. Co. KG</b> <small>Friedensinsel 73432 Aalen</small>
<small>We hereby declare that the equipment sold by us because of its design and construction, as mentioned below, corresponds to the appropriate, basic requirements of safety and health of the corresponding EC-Machinery Directive 2006/42/EC as well as to the below mentioned harmonized and national norms as well as technical specifications. In case of any modification of the equipment, not being agreed upon with us, this declaration becomes invalid.</small>	
Product name:	Load ring VLBG
<small>The following harmonized norms were applied:</small>	
EN 12100	EN 1677-1
<small>The following national norms and technical specifications were applied:</small>	
BGR 500, KAP2.8	
<small>Authorized person for the configuration of the declaration documents: Reinhard Smetz, RUD Ketten, 73432 Aalen</small>	
Aalen, 03.01.2013	Dr. Ing. Rolf Sienz, (Prokurist/DMS)
<small>Name, function and signature of the responsible person</small>	

## User Instructions - Part 2

1. Reference should be made to relevant standards and other statutory regulations. Inspections should be carried out by competent persons only.

2. Before installing and every use, visually inspect RUD lifting points, with particular attention to any evidence of corrosion, wear and weld cracks and deformations. Please ensure compatibility of bolt thread and tapped hole.

3. The material construction to which the lifting point will be attached, should be of adequate strength to withstand forces during lifting without deformation. RUD, with reference to the German testing authority BG, recommends the following minimum for bolt lengths:

- 1.5 x M in steel (minimum quality S235JR [1.0037]) ≈ AS3678 GR250.
- 1.5 x M in cast iron (for example GG 25)
- 2 x M in aluminium alloys
- 2.5 x M in aluminium-magnesium alloys
- ( M = diameter of RUD lifting point bolt, e.g. M 20 )

When lifting light metals, nonferrous heavy metals and gray cast iron, the thread has to be chosen in such a way that the working load limit of the thread corresponds to the requirements of the respective base material.

The min quality of the hexagon bolt has to be 10.9 accord. EN 24014 (DIN 931) with the nominal diameter. For replacement, the bolt can be easily hammered out (M8 - M30). The type VLBG 7t M36 is only delivered with a special bolt, therefore it is not possible to use a EN/DIN-bolt.

4. The lifting points must be positioned on the load in such a way that movement is avoided during lifting.

- a) For single leg lifts, the lifting point should be vertically above the centre of gravity of the load.
- b) For two leg lifts, the lifting points must be equidistant to/above the centre of gravity of the load.
- c) For three and four leg lifts, the lifting points should be arranged symmetrically around the centre of gravity in the same plane if possible.

5. Load Symmetry: The working load limit of individual RUD lifting points are calculated using the following formula and are based on symmetrical loading:

$$W_{LL} = \frac{G}{n \times \cos \beta}$$

WLL = required of lifting point/individual leg (kg)  
 G = load weight (kg)  
 n = number of load bearing legs  
 β = angle of inclination of the individual leg

**NOTE: For WLL Calculations**

- β angle is taken from the vertical plane.
- Included angle is the angle between the sling legs.



6. Safety: When lifting points are used in a multileg assembly, care should be taken to calculate the WLL (Working Load Limit) due to the deration caused by forces acting in multiple directions. The reduction in WLL (Working Load Limit) for multileg assemblies should be checked with relevant Standards e.g. AS 3775-2004 - Chain Slings-Gr t (8)

The lifting points should be mounted in such a way that they may easily be accessed for inspection and assembly/disassembly of the sling.

7. A plane bolting surface must be guaranteed to ensure correct mating of the lift component.

8. The VLBG has to be adjustable through 360° when fitted. For single use just tighten with spanner. For long term application and when turning loads the VLBG should be tightened to torque according to relevant table (+/- 10%). In case of turning movements (continuous operation) the recommended torques have to be checked regularly. For rotation under load RUD recommend to use the PowerPoint or WBG or WBG-V.

Adjust to the direction of pull, before attaching to the lifting means.

9. All fittings connected to the VLBG should be free moving. When connecting and disconnecting the lifting means (wire ropes, chain slings, round slings) pinches and impacts should be avoided. Damage to lifting components caused by sharp corners should also be avoided.

10. To prevent unintended dismounting through shock loading, rotation or vibration, thread locking fluid such as Loctite (depending on the application, please refer to the manufacturer's instruction) should be used to secure the bolt.

11. If the lifting points are used exclusively for lashing, the value of the working load can be doubled. LC (lashing capacity) = 2 x WLL.

12. Effects of temperature: Due to the DIN/EN bolts that are used with the VLBG the working load limit should be reduced accordingly:

-10° to 100°C	no reduction	14°F to 212°F
100° to 200°C	minus 15%	212°F to 392°F
200° to 250°C	minus 20%	392°F to 482°F
250° to 350°C	minus 25%	482°F to 662°F

Temperatures above 350°C (662°F) are not permitted.

13. RUD-Lifting points must not be used under chemical influences such as acids, alkaline solutions and vapours e.g. in pickling baths or hot dip galvanising plants. If this cannot be avoided, please contact the manufacturer indicating the concentration, period of penetration and temperature of use.

14. After fitting, an annual inspection or sooner if conditions dictate should be undertaken by a competent person examining the continued suitability. Also inspect after damage and special occurrences.

**Inspection criteria regarding paragraphs 2 and 14:**

- Ensure correct bolt and nut size, quality and length.
- Ensure compatibility of bolt thread and tapped hole - control of the torque
- The lifting point should be complete.
- The working load limit and manufacturers stamp should be clearly visible.
- Deformation of the component parts such as body, load ring and bolt.
- Mechanical damage, such as notches, particularly in high stress areas.
- Wear should be no more than 10% of cross sectional diameter.
- Evidence of corrosion.
- Evidence of cracks.
- Damage to the bolt, nut and/or thread.
- The body of the VLBG must be free to rotate.

**Any non-adherence to this advice may result in damages of persons and/or materials!**

## User Instructions - Part 3

WORKING LOAD LIMITS (G - in tonnes)				
PRODUCT DESCRIPTION	Single Leg	2, 3 or 4 Legs		
		60° 90° 120° Maximum Included Angle (Degrees)		
VLBG - 0.30t M8	0.30	0.52	0.42	0.30
VLBG - 0.63t M10	0.63	1.1	0.89	0.63
VLBG - 1.0t M12	1.0	1.7	1.4	1.0
VLBG - 1.5t M16	1.5	2.6	2.1	1.5
VLBG - 2.5t M20	2.5	4.3	3.5	2.5
VLBG - 4.0t M24	4.0	6.9	5.6	4.0
VLBG - 5.0t M30	5.0	8.6	7.0	5.0
VLBG - 7.0t M36	7.0	12.1	9.9	7.0
VLBG - 8.0t M36	8.0	13.8	11.3	8.0
VLBG - 10.0t M42	10.0	17.3	14.1	10.0
VLBG - 15.0t M42	15.0	26.0	21.2	15.0
VLBG - 20.0t M48	20.0	34.6	28.2	20.0

Table1

### Allowed lifting and turning operations

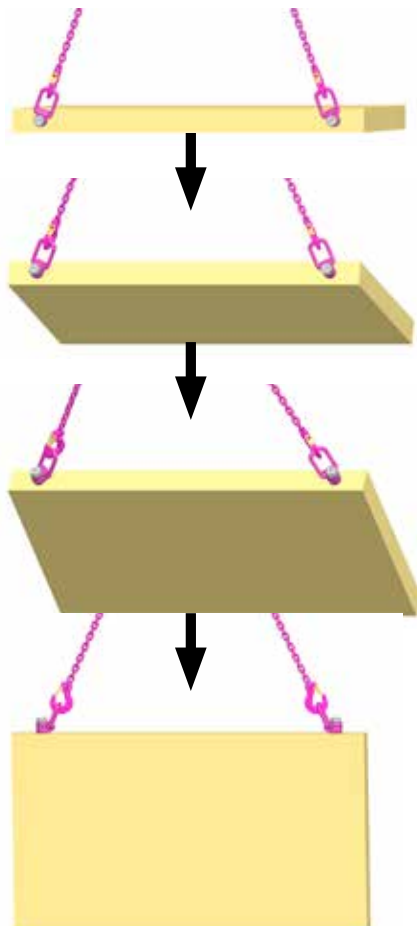

Pic 1: Possible turning operation with the VLBG

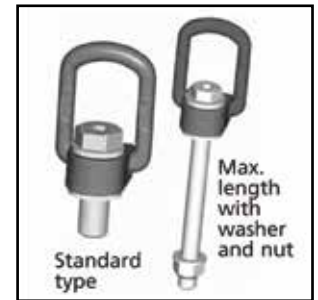
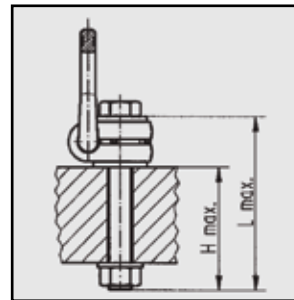
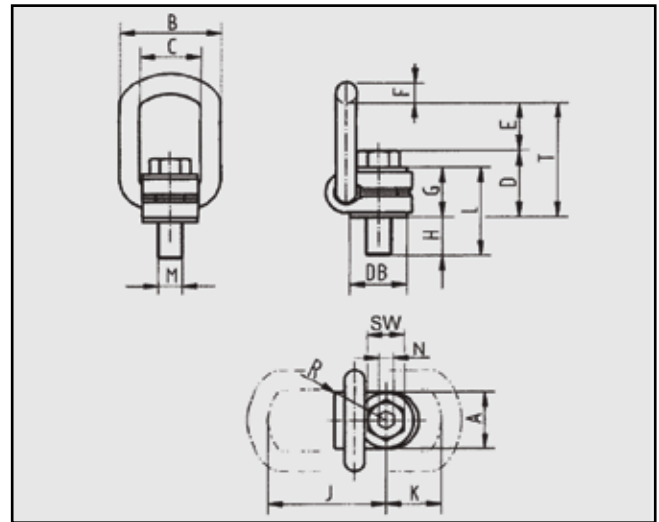

Pic 2: Pivoting in load direction

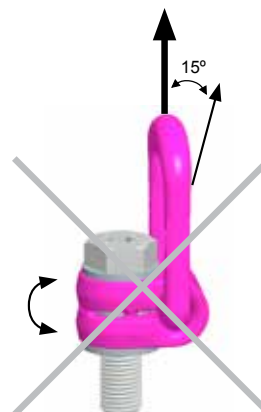

Pic 3: Forbidden turning direction at loading in the direction of the axle

# BOLT ON LIFTING POINT - VLBG LOAD RING



Type	WLL (t)	A	B	C	D	E	F	G	H stand.	H max.	J	K	L stand.	L max.	M	N	SW	R	T	DB	Weight (kg)	Torque (Nm)	Ref.-No. stand	Ref.-No. Vario (w) washer & nut
VLBG 0.3t M8	0.3	30	54	34	35	40	10	29	11	76	75	45	40	105	8	5	13	32	75	24	0.3	30	8500821	8600280
VLBG 0.63t M10	0.63	30	54	34	36	39	10	29	16	96	75	45	45	125	10	6	17	32	75	24	0.32	60	8500822	8600281
VLBG 1t M12	1	32	54	34	37	38	10	29	21	116	75	45	50	145	12	8	19	32	75	26	0.33	100	8500823	8600382
VLBG 1.2t M14	1.2	33	56	36	46	39	13.5	36	-	34	86	47	-	70	16	10	24	38	85	30	0.55	120	-	8600399
VLBG 1.5 M16	1.5	33	56	36	46	39	13.5	36	24	149	87	47	60	185	16	10	24	38	85	30	0.55	150	8500824	8600383
VLBG 2.0t M18	2.0	50	82	54	55	55	16.5	43	-	47	113	64	-	90	20	12	30	48	110	45	1.3	200	-	8600384
VLBG 2.5t M20	2.5	50	82	54	55	55	16.5	43	32	187	113	64	75	230	20	12	30	48	110	45	1.3	250	8500826	8600385
VLBG 4t M24	4	50	82	54	58	67	18	43	37	222	130	78	80	265	24	14	6	48	125	45	1.5	400	8500827	8600386
VLBG 4t M27	4	60	103	65	78	69	22.5	61	39	-	151	80	100	-	27	-	41	67	147	60	3.1	400	7983658	-
VLBG 5t M30	5	60	103	65	80	67	22.5	61	49	279	151	80	110	340	30	17	46	67	147	60	3.1	500	8500828	8600388
VLBG 7t M36	7	60	103	65	72	74	22.5	55	52	-	151	80	107	-	36	-	55	67	146	60	3.3	700	8500829	-
VLBG 8t M36	8	77	122	82	100	97	26.5	77	63	223	205	110	140	300	36	22	55	85	197	70	5.8	800	7983553	8600289
VLBG 10t M42	10	77	122	82	103	94	26.5	77	73	273	205	110	150	350	42	24	65	85	197	70	6.4	1000	7983554	8600290
VLBG 15t M42	15	95	156	100	113	109	36	87	63	263	230	130	150	350	42	24	65	100	222	85	11.2	1500	7982966	8600291
VLBG 20t M48	20	95	156	100	117	105	36	87	73	303	230	130	160	390	48	27	75	100	222	95	11.6	2000	7982967	8600292
VLBG-Z 1t 1/2"-13UNC	1	32	54	34	38	37	10	29	22	-	75	45	51	-	1/2"	-	3/4"	32	75	26	0.33	100	8502349	-
VLBG-Z 1.5t 5/8"-11UNC	1.5	33	56	36	47	38	13.5	36	24	-	87	47	60	-	5/8"	-	15/16"	38	85	30	0.55	150	8502350	-
VLBG-Z 2.5t 3/4"-10UNC	2.5	50	82	54	56	54	16.5	43	28	-	113	64	71	-	3/4"	-	1 1/8"	48	110	45	1.3	250	8502351	-
VLBG-Z 2.5t 7/8"-9UNC	2.5	50	82	54	58	52	16.5	43	27	-	113	64	70	-	7/8"	-	1 5/16"	48	110	45	1.3	300	8502352	-
VLBG-Z 4t 1"-8UNC	4	50	82	54	61	64	16.5	43	41	-	130	78	84	-	1"	-	1 1/2"	48	125	45	1.5	400	8502353	-
VLBG-Z 5t 1 1/4"-7UNC	5	60	103	65	80	64	22.5	61	41	-	151	80	102	-	1 1/4"	-	1 7/8"	67	147	60	3.3	500	8503187	-

Table 2