



Tiger Lifting



www.tigerlifting.com

Home of the Tiger hoisting range & Tiger subsea lifting products

Tiger SS11 Subsea Lever Hoist



(with overload protection)

Main Features

- Now available with slipping clutch overload protection
- Range from 800kg – 20000kg
- *NEW* Patented Twin Cam shaped pawl design
- Certified and proven track record
- Double switch brake mechanism
- Marine specific friction discs
- Meets and exceeds IMCA DO28 Rev 1 guidance notes for offshore lever hoists
- Light load protection at 2% of the rated capacity
- Lifts, holds and lowers the load at 2% of rated capacity
- No requirement for preload tension to activate the ratchet mechanism
- Anti-corrosive protection to ensure reliable long term use
- *NEW* external corrosion protection
- Adaptable to use both inverted and horizontally
- Brake chamber protection from outside contamination
- High performance premium grease
- Stainless steel fixings and fasteners
- -40°C to +50°C Operating temperature range
- *NEW* adjustable chain end anchorage
- Also available with stainless steel load chain or spark resistant hooks
- Meets or exceeds all international standards





Tiger SS11 Subsea Lever Hoist

The SS11 has been designed and developed over a number of years for use primarily in the Subsea environment. The design and anti-corrosion features incorporated in the SS11 hoist range give it significant safety advantages over standard lever hoists, making the hoist the ideal tool for all Marine and extreme applications.

Developed initially with the goal of giving key stakeholders within the Oil and Gas Industry a hoist that could be certified for safe use Subsea whilst meeting all the requirements of IMCA DO28 Rev. 1 "Guidance notes for offshore lever hoists", the SS11 meets and exceeds these requirements, as well as conforming to standards such as BS EN 13157: 2004+A1:2009, ANSI/ASME B30.21, AS1418.2 and SANS 1636.

With over 50 years of professional manufacturing experience, Tiger's commitment to innovation and customer satisfaction mean we will continue to develop and improve our products by communicating and working with our customers. The SS11 range of Subsea lever hoists is evidence of this practice.

Certification:

Each unit comes fully certified with a test certificate or an EC Declaration of Conformity stating compliance with the essential health and safety requirements of the Machinery Directive 2006/42/EC. This document clearly states the proof test at 1.5 times the rated capacity and the light load test of 2% of the rated capacity, which exceeds the requirements of the current applicable standard.

Double Brake:

The SS11 comes with a unique dual brake mechanism that automatically engages when the lever hoist feels the slightest resistance on the bottom hook. This key feature means that the SS11 will raise, hold and lower the lightest of loads without slipping. The two stage process protects against accidental light load failures by putting the hoist into neutral whilst under load.

Light Load Protection:

The unique brake system designed for the SS11 guarantees a light load protection at 2% of the rated capacity.

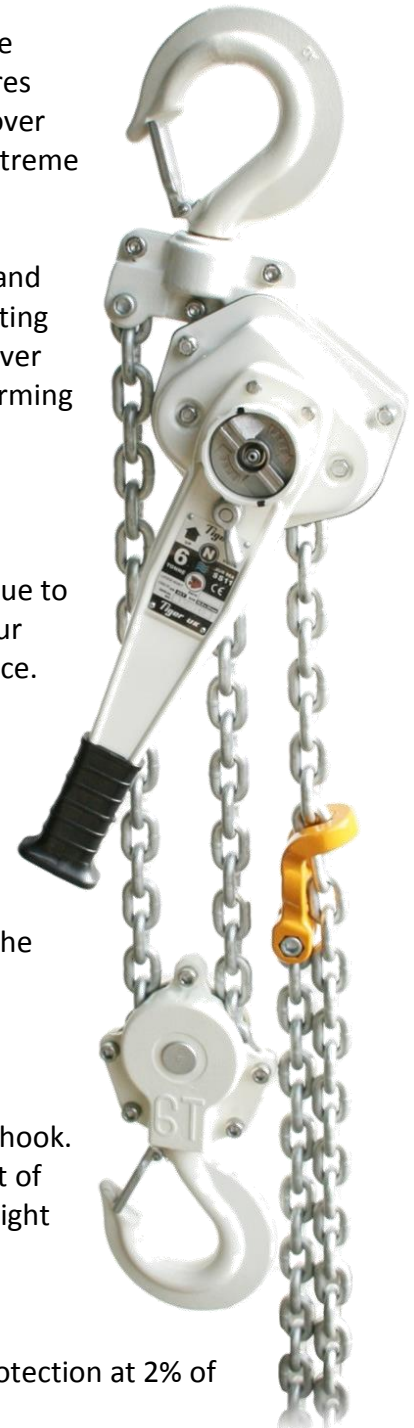



Cam Type Brake Pawls:

This latest development in brake efficiency guarantees permanent engagement of at least one of the twin reciprocating cam pawls fitted to the SS11, ensuring the pawl only just clears the ratchet wheel, with the minimum of clearance as required under BS 4898:1973. But most importantly, in the unlikely event of a pawl spring failure, this new design will ensure the brake is still fully functional and the load is sustained without damage to the mechanism.

Anti-Corrosion Protection:

Critical internal components are protected by our OCP (Organic Compound Protection) finish giving unprecedented long term reliability. OCP has been proven to be effective through 1000 hours of the ASTM B117 Salt Spray Test. The SS11 is NOW externally finished with our own anti-corrosion finish giving the SS11 body over 1000 hours of protection under the same test criteria, whilst maintaining a high degree of impact protection.

Marine Friction Discs:

Developed and designed for Subsea use creating a highly efficient, reliable braking surface for use in the most extreme conditions.

Brake Chamber Protection:

Precisely engineered side plates and components are protected by a full gasket giving the SS11 brake chamber and contents maximum protection from external contamination.

Load Protection:

Security of the load is achieved by full engagement of the heavy duty spring latch into the recessed nose of the hook safeguarding the load when side loading of the latch occurs.

Overload protection:

Designed for maximum safety, comfort, efficiency and ease of use, the operator friendly Hammerhead handle prevents the use of unauthorised extension bars overloading the SS11

Load Chains:

Tiger only use the highest quality alloy, calibrated load chains in Grade 80 (T) or 100 (V). The SS11 comes as 3.0mtr HOL as standard but can be chained up to whatever length is required. Stainless steel load chain available on request for certain capacities.

Protection:

The SS11 has OCP protection on all the internal parts including load and hand chains ensuring over 1000 hours continuous protection.

Finish:

The SS11 is finished in our high quality white Akzo Nobel powder coat paint offering excellent additional corrosion protection. (Data sheets available on request.)





Tiger Lifting



www.tigerlifting.com

Tiger

Home of the Tiger hoisting range & Tiger subsea lifting products



Hooks:

Drop forged and heat treated alloy hooks are furnished with heavy duty latch kits that fully engage into the nose of the hook offering maximum load security. The swivel hooks are attached to the yoke using high grade nuts & bolts allowing for complete inspection during any statutory inspection or written scheme maintenance. The entire hook fitting has been protected using OCP or stainless steel fixtures and fittings. Also available with spark resistant hooks.



Forgings:

Recessed forgings offer full protection to the load chain anchor bolts on all our bottom hooks.



Chain end anchorage:

Tiger have incorporated the ultimate safeguarding of a single point failure mode as described in IMCA DO28 Rev. 1 Note 7.2 by installing a new specially designed adjustable chain end stop profiled to fit the contours of the hoist body. This offers complete assurance to the operator, whilst maintaining the flexibility of "freewheeling" the chain to any required starting position.



Chain Guide:

Specifically designed to guide the load chain safely onto or off the load sheave without snagging or jamming, the fluted chain stripper allows the safe use of the SS11 when used in any orientation.





High Performance Premium Grease:

Load carrying ability, mechanical stability, corrosion protection, water resistance and increased operating temperature ranges are all improved by the using only the very best lubricant.

Performance:

The SS11 lever hoist has undergone a full test program that includes:

Type Testing

- Ultimate strength test, at least 4 times the Working load limit (WLL)
- Chain end anchorage test, passing at least 4 times the WLL without any restriction of the brake or gears

Test on every hoist

- Proof loading at 1.5 times the rated capacity
- Light load testing at maximum of 2% rated capacity

Salt Spray – Submersion Test Programme:

The SS11 range of hoists has successfully been type tested to over 1000 hours continuous exposure to an industry generated test programme that was specifically drawn up and agreed upon by a group of independent professionals incorporating ASTM B117 environmental conditions. This programme included over 50 individual load tests on the same hoist of varying weights at various timescales, to fully challenge the SS11.

Technical Data

Product Code	Capacity (tonne)	Effort (kg)	Dimensions (mm)								Load Chain		Standard HOL (m)	Mass @ std HOL (kg)	Mass for extra metre HOL (kg)
			A	B	C	D	E	F	F1	F2	Diameter (mm)	No. of falls			
SS-0080	0.8	23	128	240	275	158	99	33	28	44	ø6.3	1	3	9.1	0.86
SS-0150	1.5	26	154	360	320	172	104	38	34	48	ø7.1	1	3	12.6	1.07
SS-0300	3.0	38	182	360	400	195	108	40	35	54	ø10.0	1	3	22.0	2.17
SS-0600	6.0	40	242	360	570	195	108	54	50	68	ø10.0	2	3	36.5	4.34
SS-1000	10.0	47	370	360	630	195	108	60	54	90	ø10.0	3	3	56.3	6.54
SS-2000	20.0	43	470	370	1050	251	161	90	70	105	ø10.0	6	3	174.0	13.08

See page 7 for more hook information





Tiger Lifting



www.tigerlifting.com

Tiger

Home of the Tiger hoisting range & Tiger subsea lifting products

Technical Drawings

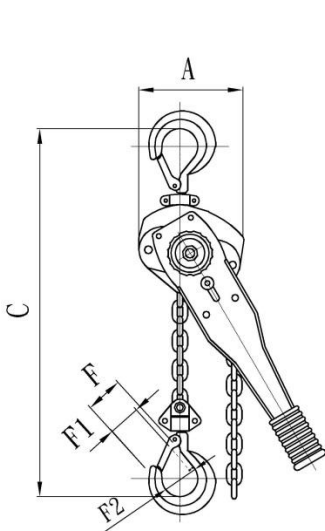

0.8t and 3.0t

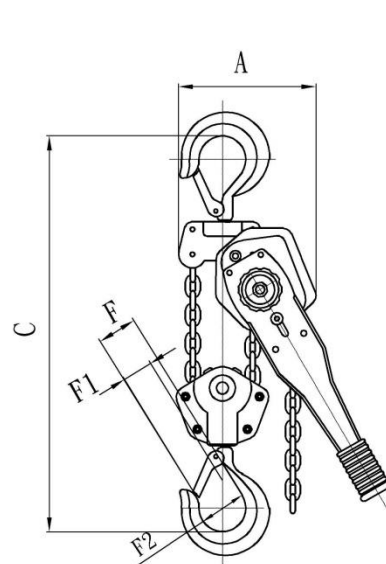

6.0t

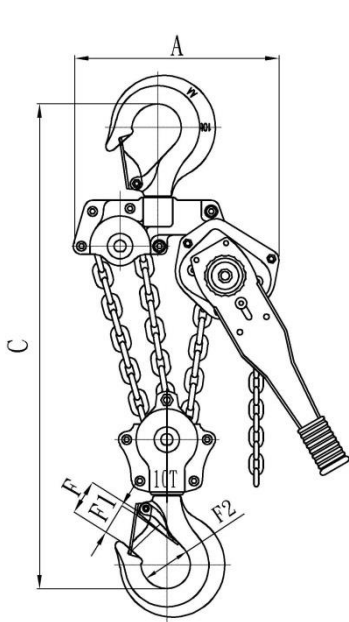

10.0t

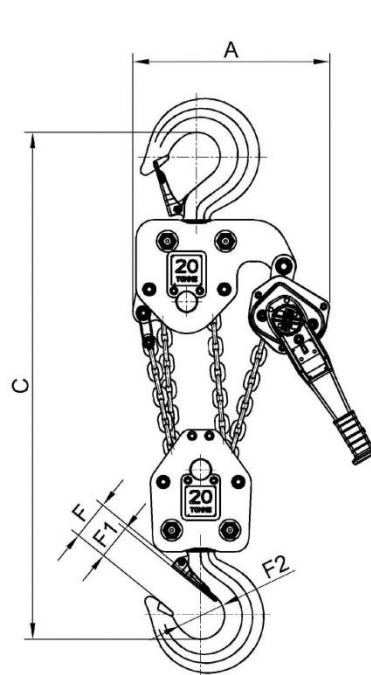

20.0t





Hook Technical Data

Capacity (Tonnes)	Collar measurements (mm)		Hook thickness at point shown in diagram (mm)		Hook throat Opening (mm)	"EZ Check" measurement (mm)
	a	b	c	d	e	f
0.8	8	13.5	23	17	33	52
1.5	10	15.5	26	21	38	59
3.0	12.5	20	37	32	40	76
6.0	19	30	43	36	54	86
10.0	20	33	52	48	60	121
20.0	-	48	77	72	90	162

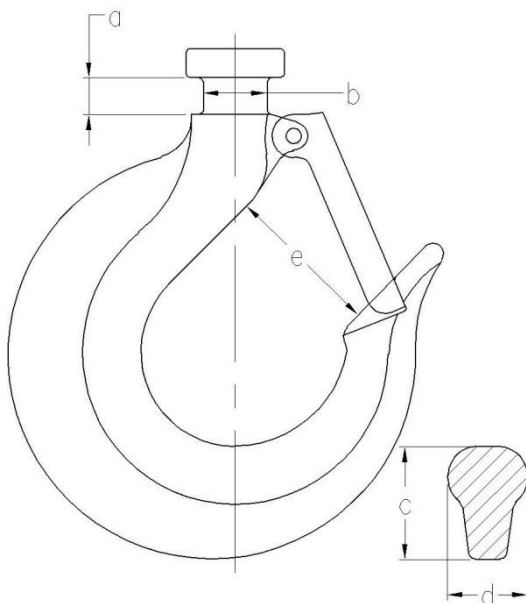

Traditional Tiger Hooks

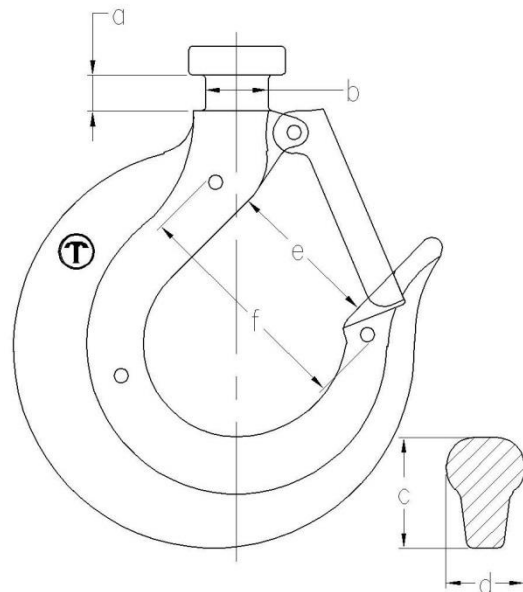

Tiger Hooks with new "EZ Check"
3 point marking system



Tiger Lifting



www.tigerlifting.com

Tiger

Home of the Tiger hoisting range & Tiger subsea lifting products

Newer models are fitted with the patent pending Tiger “EZ check” 3 point marking system. With this system a quick check that the A and B measurements are the same (as shown in the diagram below) will indicate if the hooks have stretched. If $A \leq B$ the hook is fine; If $A > B$ the hook needs to be replaced:

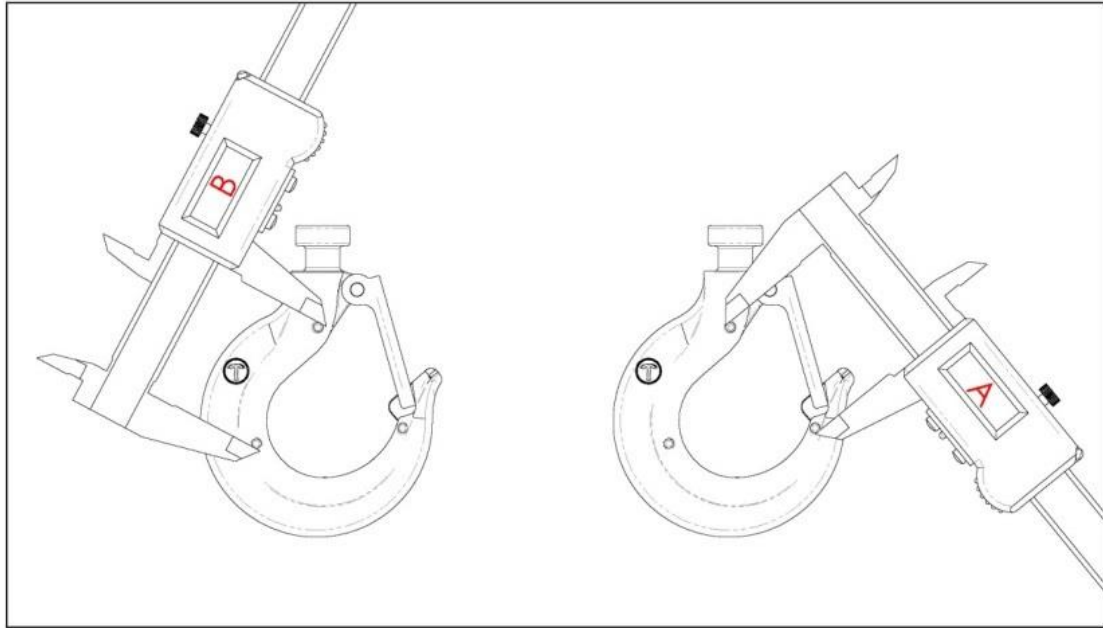

Due to our policy of continual product development, dimensions, weights and specifications may change without prior notice. Please check with your Tiger sales team when ordering.

