

Tiger Heavy Duty Beam Clamp Model No BC

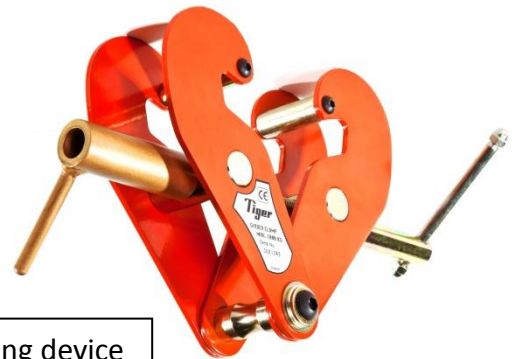

Main Features

- Range from 1.0t to 10.0t
- Quick and versatile rigging point for hoisting equipment
- Low headroom because of the built in anchor point
- Multidirectional adjusting screw spindle for easy attachment and safe and secure grip
- Wide Beam flange adjustment range
- Safety factor up to 5 times SWL



With optional locking device

These units meet and exceed all the requirements within BS EN 13155:2003+A2:2009 and AS4991.

Certification:

Each unit comes fully certified with a test certificate or an EC Declaration of Conformity stating compliance with the essential health and safety requirements of the Machinery Directive 2006/42/EC.

Technical Data

Product Code	Capacity (tonne)	Dimensions (mm)								Weight (kg)
		A	B	C	D	E	F	G	øJ	
BC-0100	1.0	72-210	182-328	77	26	190	144-117	52-38	Ø20	4.5
BC-0200	2.0	75-210	182-328	85	26	190	144-117	52-38	Ø20	5.2
BC-0300	3.0	73-305	214-460	107	35	240	224-179	58-40	Ø22	9.1
BC-0500	5.0	73-305	214-460	121	35	240	224-175	58-40	Ø28	10.7
BC-1000	10.0	90-330	289-496	135	36	277	231-182	75-58	Ø38	22.2

Technical Drawing

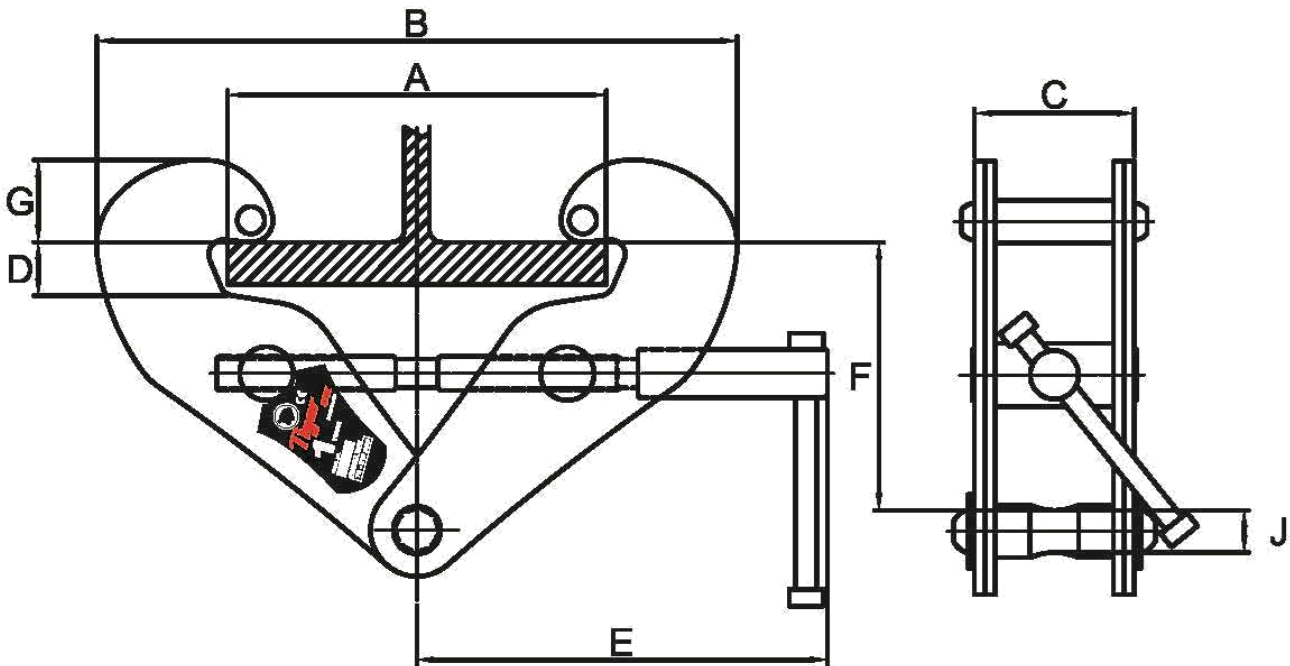

Due to our policy of continual product development, dimensions, weights and specifications may change without prior notice. Please check with your Tiger sales team when ordering.

