

# STEERMAN<sup>®</sup>

LOAD MOVING SYSTEMS



## Operating Instructions

*Including:*

- Safety warnings
- General arrangement drawings and parts list
- Features and benefits
- Product material data

Columbus McKinnon Corporation Limited  
Knutsford Way, Sealand Industrial Estate, Chester CH1 4NZ  
Tel: 01244 375375 Fax: 01244 377403  
Email: sales@steerman.co.uk Web Site: www.steerman.co.uk



## GENERAL INFORMATION

Thank you for choosing a Steerman Load Moving System. Before assembling and using the system, please read these instructions thoroughly and retain them for future reference. These instructions cover ten models: the SX5, SX10, SX15, SX20, SX25, SX30, S40, S60, S80 and the S100.

Steerman Load Moving Systems have been designed to professionally transport loads weighing up to 100 tonnes. Each system includes a steerable front section and a pair of independent rear trolleys which together enable excellent manoeuvrability of almost all types of industrial loads.

Specially formulated composite wheels give extremely low rolling resistance and help prevent damage to modern industrial floors.

Before using your Steerman Load Moving System you must read the following warnings and comply with all instructions. For any additional advice on the safety and suitability of this equipment please contact your supplier, as noted on the front cover, before operating the system.

**There is a serious risk of personal injury if you do not follow all instructions detailed in this booklet.**

This equipment is designed to be used on smooth industrial floors by an able bodied, competent adult who has read and understood these warnings and instructions.

**This equipment MUST NOT be used to carry or lift personnel.**

Make sure that you know how to operate this equipment safely and are aware of its limitations before you attempt to use it. Make sure that everyone in the immediate work area is warned of what you are doing and is aware of the path you plan the load to take.



## ALWAYS...

**Always** wear practical, protective clothing, gloves and footwear. Avoid loose garments and jewellery that could catch in moving parts, and tie back long hair.

**Always** check that the wheels are free of embedded debris before using the system.

**Always** use on a smooth level surface with the load unevenly distributed on the system.

**Always** use some form of anti-slip mat or wooden board between the three system support points and the load.

**Always** keep hands and feet well clear of all areas beneath the load being raised or carried.

**Always** operate the equipment within its rated capacity. Do NOT overload.

**Always** keep fingers clear of the front wheel boxes when lifting the system. These boxes are designed to swivel.

**Always** avoid shock loading when positioning or carrying industrial loads.

**Always** use jacks to lift and lower loads onto any Steerman Load Moving System rather than lowering directly from a crane or fork lift truck.

**Always** ensure that the rear trolleys are kept in line by using the Steerman alignment bar supplied with the system.

**Always** keep children, animals and bystanders away from the work area. Cordon off a NO-GO area using either cones, barriers or tape.

# MODEL S100 TOTAL SYSTEM CAPACITY 100 TONS

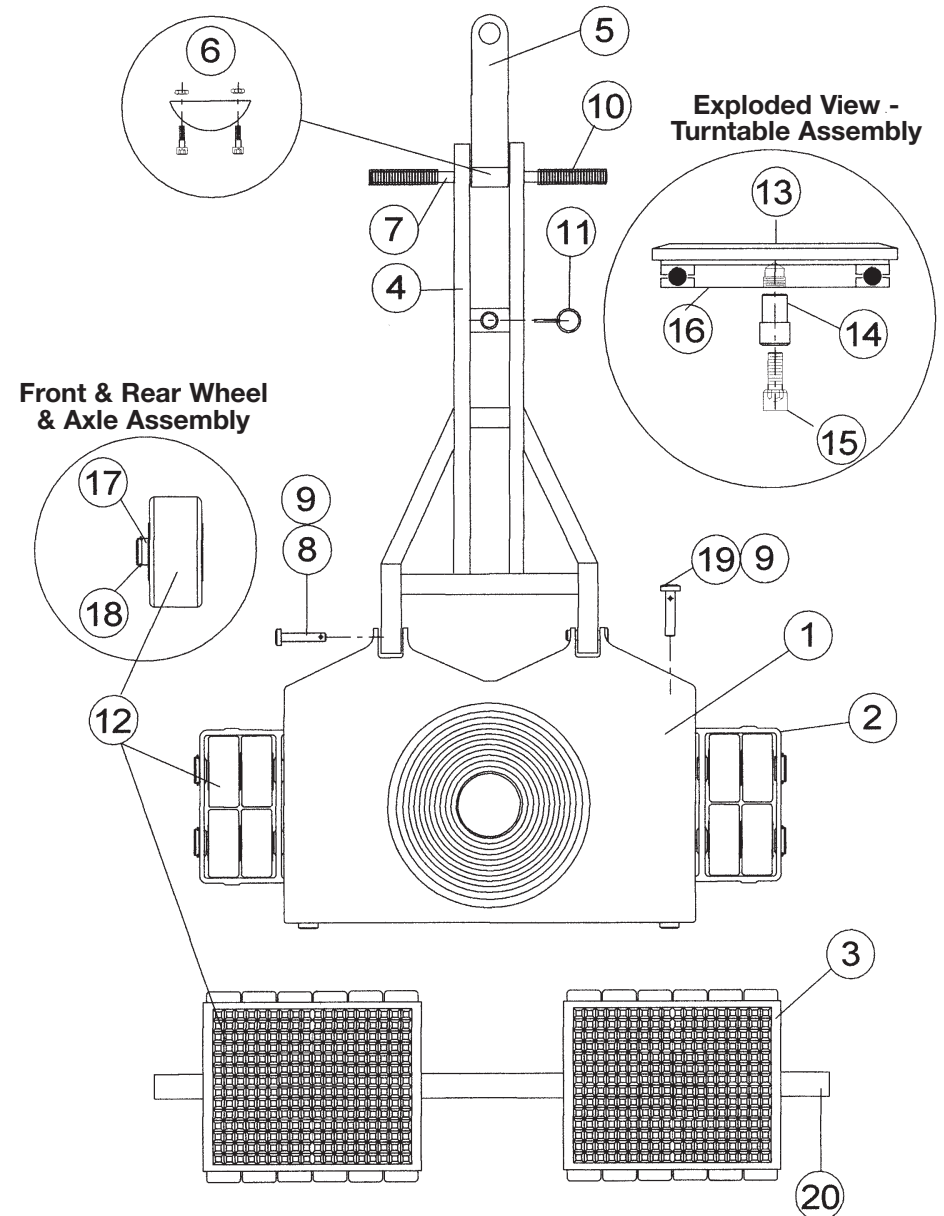

# MODEL S100 - PARTS LIST

Item	Description	Part No.	Parts per system
1	Front Frame	S011080	1
2	Front Wheel Box - Casting	S011081	2
3	Rear Trolley - Casting	S011082	2
4	Handle	S011083	1
5	Tow Eye	S011084	1
6	Rubber Bump Stop	S011065	1
7	Pivot Shaft- Handle	S011086	1
8	Pivot Pin - Handle	S011087	2
9	"R" Clip - Pivot Pin (6mm)	S011068	6
10	Rubber Handle Grips	S011005	2
11	Lynch Pin - Tow Eye Retention	S011099	2
12	Wheel Assembly (Black)	S011090	48
13	Turntable (Black)	S011091	1
14	Collar - Turntable Bolt	S011092	1
15	Turntable Bolt	S011092	1
16	Turntable Bearing	S011073	1
17	Axle Shaft (Front & Rear)	S011094	8
18	Circlip	S011095	16
19	Pivot Pin	S011096	4
20	Alignment Bar	S011097	1

\* Each Wheel Assembly comes complete with nylon wheel and two bearings fitted

## TECHNICAL DATA (METRIC)

### STEERABLE FRONT UNIT

Maximum Load	50 tonnes
Wheels (black)	24 @ 150 mm dia
Turntable Diameter	425 mm
Overall Loading Height	210 mm
Handle Length	1,910 mm

### ADJUSTABLE REAR UNITS

Maximum Load	50 tonnes
Wheels (black)	24 @ 150 mm dia
Load Area	2 @ 380 x 495 mm
Overall Loading Height	210 mm
Width Adjustment	990 - 2,000 mm

Total boxed weight of the Steerman S100 system is 525 kgs

## TECHNICAL DATA (IMPERIAL)

### STEERABLE FRONT UNIT

Maximum Load	50 tons
Wheels (black)	24 @ 5 7/8" dia
Turntable Diameter	16 3/4"
Overall Loading Height	8 1/4"
Handle Length	75"

### ADJUSTABLE REAR UNITS

Maximum Load	50 tons
Wheels (black)	24 @ 5 7/8"
Load Area	2 @ 15" x 19 1/2"
Overall Loading Height	8 1/4"
Width Adjustment	39" - 79"

Total boxed weight of the Steerman S100 system is 1157 lbs



## DO NOT...

- Do not** use the equipment until you have read and fully understood these instructions.
- Do not** operate the equipment if you are ill, feeling tired, or under the influence of alcohol or drugs.
- Do not** operate the equipment until you have checked that no damage to the system has occurred from previous use and that it has been correctly reassembled.
- Do not** operate the equipment until it has been ascertained that the weight and center of gravity of the load being carried is in the center of the 3 point load system.
- Do not** attempt to raise loads when they are close to ceilings or other overhead obstructions.
- Do not** operate the equipment until you have ensured that the load is balanced, stable and that all personnel are standing clear of the load and the route to be travelled.
- Do not** operate the equipment on inclined surfaces.
- Do not** operate the equipment where contact with acids, alkalis or strong solvents is likely.
- Do not** operate the equipment over rough or uneven surfaces, floor joints, sliding door tracks, man hole covers, tarmac or asphalt.
- Do not** operate the equipment over any surface that is unable to adequately support the weight of the load and system together.



## OPERATING INSTRUCTIONS

### Getting Started:

Ensure that you have selected a set of Steerman skates that are designed to carry the full weight of your intended load.

Have available all necessary lifting jacks, restraining equipment and pulling or pushing devices needed for the job.

Assess the shape of the load to determine the best position for the skates. Remember the load must rest evenly on the three top pads of the Steerman system with half the weight on the two rear trolleys and the other half on the front steer section.

Always raise the rear part of the load first, using hydraulic claw jacks, then place the two rear trolleys in position. Ensure that some form of anti-slip mats or wooden boards are in place between the load and the two trolleys. The Steerman alignment bar should be positioned perpendicular to the direction of travel to avoid "crabbing" when the load is moved. Carefully lower the load onto the rear trolleys and remove the jacks.

Next, jack up the front of the load and position the front steering unit (fitted with a turntable). Again, ensure that an anti-slip mat or wooden board is in place on the turntable pad.

Lower the load onto the steerable front section and double check that the load is evenly distributed and safely balanced.



## OPERATING INSTRUCTIONS

continued...

If the skates need to be manoeuvred beneath the load before lowering onto the system, use a broom handle or similar. Under no circumstances should anyone allow their hands or feet to be directly under the load at any time.

Check that the route to the destination is clear and the surface is suitable for both the weight of the load and the shifting skates.

Totally clear and clean the floor area and route to be travelled remove oil, grease, metal shavings, or debris. Remember, Steerman skates have only been designed to operate over smooth, modern industrial floors.

### Basic Techniques:

The front skate must not be steered while the load is stationary. Steering can only occur when the load is moving.

When the system is moving, always position yourself so that you can control the skates while at all times staying clear of the load.

Extreme care should be taken to ensure that any operator, lookout or bystander does not get trapped between the load and any surrounding walls or obstructions.

When pushing or pulling with a powered vehicle, secure a restraint cable or sling to the load to prevent it running away.

The operator should be within sight of powered vehicle driver at all times. If this is not possible, a third person should be used to relay instructions between the operator and the driver.

Whenever possible it is of great help to mark the floor to show the exact route where the load is to travel and where it is to be finally positioned.

Check the path for debris before the operation and continually check behind you as you steer to make sure there is no danger of tripping or falling.

Do not allow the load system to travel at speed or abruptly change its direction of travel.



## FINALLY

To remove the Steerman System from beneath the load, the load should be raised on hydraulic claw jacks until it is just clear of the system. The front steer unit should be removed first and the load lowered to the floor before attempting to remove the rear units.

Next, the rear trolleys should be removed and the load lowered to the ground gradually and under total control.

Before manually lifting any part of the Steerman Load Moving System, check that the component weight does not exceed 20kgs (44lbs).

**Take your time and exercise extreme care. You are more likely to have an accident if you are tired or rushing to complete any operation.**

## MODEL S80 TOTAL SYSTEM CAPACITY 80 TONS

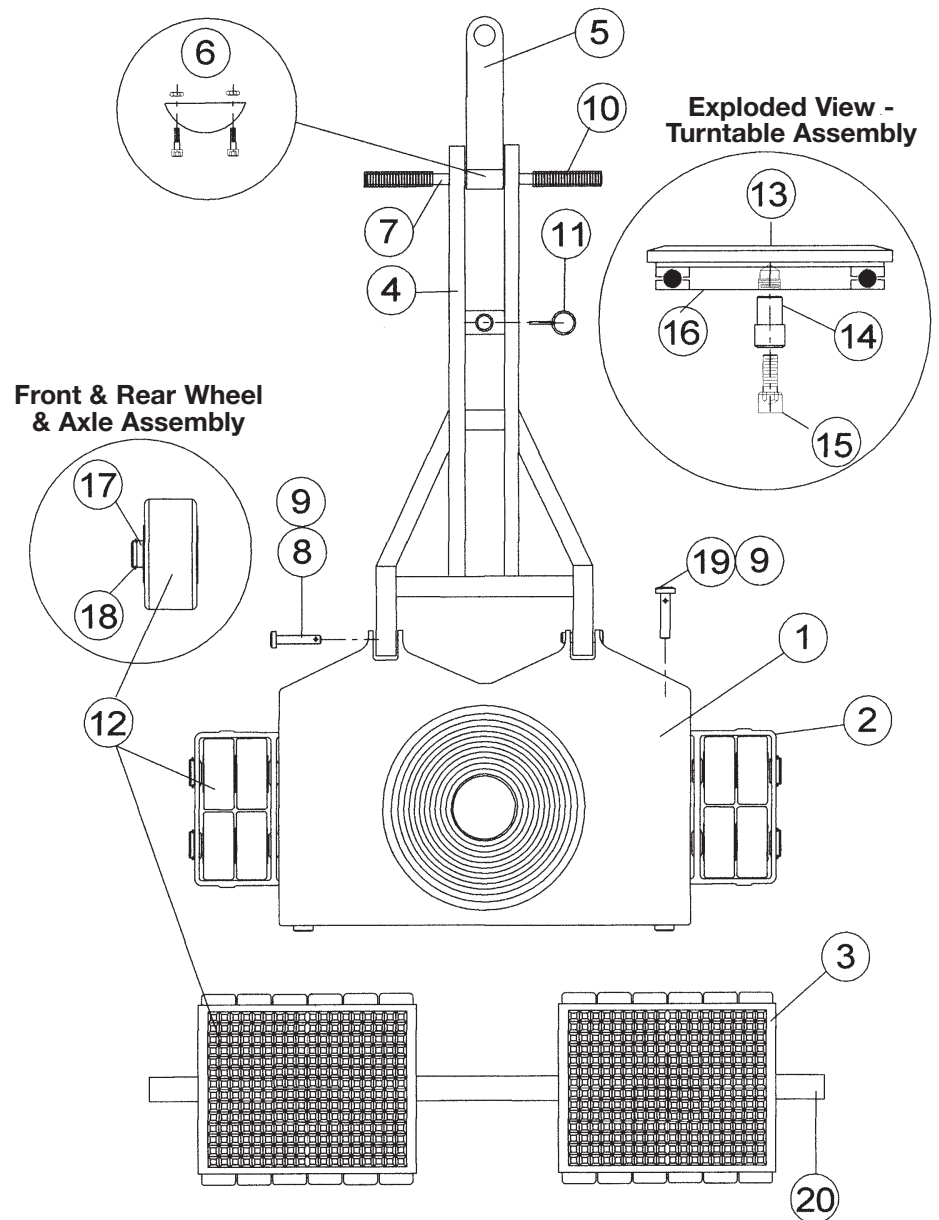

# MODEL S80 - PARTS LIST

Item	Description	Part No.	Parts per system
1	Front Frame	S011080	1
2	Front Wheel Box - Casting	S011081	2
3	Rear Trolley - Casting	S011082	2
4	Handle	S011083	1
5	Tow Eye	S011084	1
6	Rubber Bump Stop	S011065	1
7	Pivot Shaft- Handle	S011086	1
8	Pivot Pin - Handle	S011087	2
9	"R" Clip - Pivot Pin (6mm)	S011068	4
10	Rubber Handle Grips	S011005	2
11	Lynch Pin - Tow Eye Retention	S011099	2
12	Wheel Assembly (Blue)	S011079	48
13	Turntable (Black)	S011091	1
14	Collar - Turntable Bolt	S011092	1
15	Turntable Bolt	S011092	1
16	Turntable Bearing	S011073	1
17	Axle Shaft (Front & Rear)	S011094	8
18	Circlip	S011095	16
19	Pivot Pin	S011096	4
20	Alignment Bar	S011097	1
21	"R" Clip - Pivot Pin (7mm)	S011098	2

\* Each Wheel Assembly comes complete with nylon wheel and two bearings fitted

## TECHNICAL DATA (METRIC)

### STEERABLE FRONT UNIT

Maximum Load	40 tonnes
Wheels (blue)	24 @ 150 mm dia
Turntable Diameter	425 mm
Overall Loading Height	210 mm
Handle Length	1,910 mm

### ADJUSTABLE REAR UNITS

Maximum Load	40 tonnes
Wheels (blue)	24 @ 150 mm dia
Load Area	2 @ 380 x 495 mm
Overall Loading Height	210 mm
Width Adjustment	990 - 2,000 mm

Total boxed weight of the Steerman S80 system is 525 kgs

## TECHNICAL DATA (IMPERIAL)

### STEERABLE FRONT UNIT

Maximum Load	40 tons
Wheels (blue)	24 @ 5 7/8" dia
Turntable Diameter	16 3/4"
Overall Loading Height	8 1/4"
Handle Length	75"

### ADJUSTABLE REAR UNITS

Maximum Load	40 tons
Wheels (blue)	24 @ 5 7/8" dia
Load Area	2 @ 15" x 19 1/2"
Overall Loading Height	8 1/4"
Width Adjustment	39" - 79"

Total boxed weight of the Steerman S80 system is 1158 lbs



## FEATURES & BENEFITS

### "Three point load carrying principle"

Benefits: -

1. Ensures you have a stable configuration.
2. Eliminates the risk of one skate moving from beneath the load.

### "Frame components manufactured from Spheroidal Graphite Iron"

Benefits: -

1. Immensely strong material, which is professionally powder coated prior to assembly.
2. Allows system sizes to be kept to a minimum.
3. Enables precise reproduction of design features.

### "Specially developed composite wheels machined from solid stock"

Benefits: -

1. Material is hard and ensures you have an extremely low rolling resistance.
2. Sufficiently pliable to reduce damage to painted or resin sealed floors.

### "Innovative wheel and bearing design"

Benefits: -

1. Two shielded ball bearing assemblies are fitted to each wheel.
2. Narrow wheel design reduces scuffing and greatly improves manoeuvrability.
3. All bearings have a unique extended inner race giving excellent rolling clearance.

### "Unique Steerman designed turntables"

Benefits: -

1. Special composite material is CNC machined from solid stock.
2. Only 20% of the weight of a steel equivalent, it has superior impact resistance.
3. All turntables are supported on large thrust bearings, preventing loads being imposed unevenly.



## PRODUCT MATERIAL DATA

### SX Series Machine Skates Cast Frames

All Steerman systems (with the exception of the SX5 front frame which is fabricated) are produced from Spheroidal Graphite Cast Iron also known as Ductile Iron. The material is produced in accordance with the British Standard BS 2789: 1985 (now known as BS EN 1563: 1997) the material designation is 420 - 12.

The castings are produced in resin bonded rigid sand moulds for repeated accuracy. The SG Iron is melted using electric induction furnaces for complete material control.

The ductile material is very resilient in service, providing a higher carrying capacity to weight ratio than conventionally fabricated steel frames, which are usually much bigger and heavier.

All SX series frame designs were subject to finite element analysis during the design stage. Destructive testing was completed during development with satisfactory results:

In all test case the castings did not fracture, they simply deformed at the designed point of yield.

### Cast Nylon Wheels and Turntables

There are 2 types of cast nylon material used for the product of the wheel assembly, simply identified by their colours BLACK or BLUE. The black wheels having approximately 25% greater load carrying capacity in comparison to the blue. Both types of material have similar mechanical properties with a much improved performance compared with natural cast nylons. The wheels are machined from bar stock and the bearings are pressed into place to complete the assembly.

Compared with natural cast nylons BLACK Moly and HSBLUE gives:

- Increased superficial hardness provides excellent machineability
- Improvement in wear properties as a result of dry lubricant - black.
- Improved anti-friction properties.
- Higher operating temperatures up to a maximum continuous of 105° C
- Lower water absorption.
- Improved dimensional stability.
- Excellent chemical resistance properties.
- Higher load bearing capabilities.

Both materials provide high resistance to shattering and deformity when striking debris in use where normal natural cast nylons would fail.

### Turntable

The cast nylon turntable absorbs a large percentage of any dynamic load placed on the turntable assembly, this can occur through natural means such as the movement of the skates with a load or the extreme case where a load is lowered by a crane onto the turntable (not recommended).

## MODEL S60 TOTAL SYSTEM CAPACITY 60 TONS

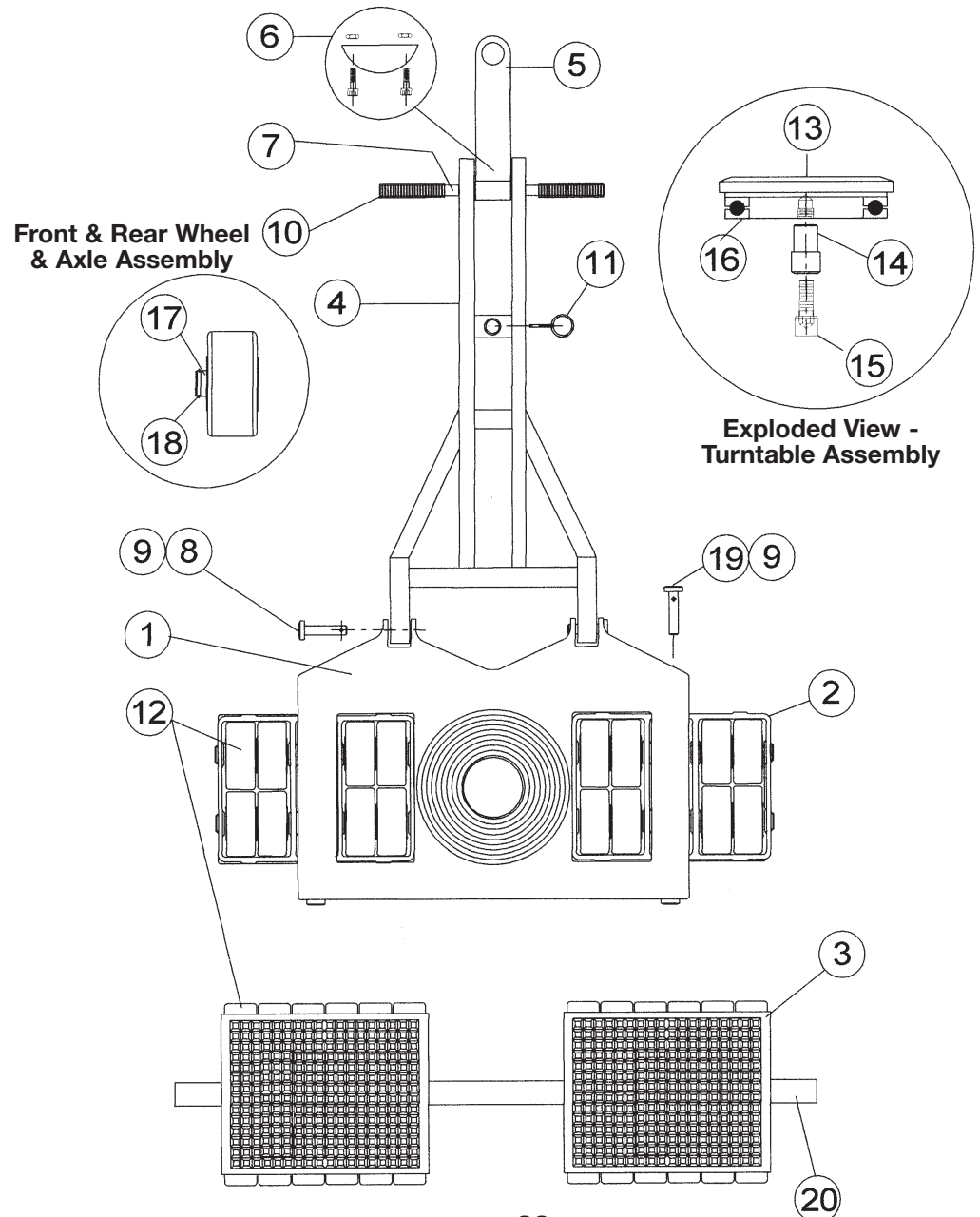

# MODEL S60 - PARTS LIST

Item	Description	Part No.	Parts per system
1	Front Frame	S011060	1
2	Front Wheel Box-Casting	S011061	2
3	Rear Trolley Casting	S011062	2
4	Handle	S011063	1
5	Tow Eye	S011064	1
6	Rubber Bump Stop	S011065	1
7	Pivot Shaft-Handle	S011066	1
8	Pivot Pin - Handle	S011067	2
9	"R" Clip - Pivot Pin (6mm)	S011068	6
10	Rubber Handle Grips	S011005	2
11	Lynch Pin - Tow Eye Retention	S011099	2
12	Wheel Assembly (Black)	S011078	48
13	Turntable (Black)	S011071	1
14	Collar - Turntable Bolt	S011072	1
15	Turntable Bolt	S011072	1
16	Turntable Bearing	S011073	1
17	Axle Shaft (Front & Rear)	S011074	8
18	Circlip	S011075	16
19	Pivot Pin	S011076	4
20	Alignment Bar	S011077	1

\* Each Wheel Assembly comes complete with nylon wheel and two bearings fitted

## TECHNICAL DATA (METRIC)

### STEERABLE FRONT UNIT

Maximum Load	30 tonnes
Wheels (black)	24 @ 115 mm dia
Turntable Diameter	350 mm
Overall Loading Height	170 mm
Handle Length	1,750 mm

### ADJUSTABLE REAR UNITS

Maximum Load	30 tonnes
Wheels (black)	24 @ 115 mm dia
Load Area	2 @ 300 x 400 mm
Overall Loading Height	170 mm
Width Adjustment	800 - 2,000 mm

Total boxed weight of the Steerman S60 system is 302 kgs

## TECHNICAL DATA (IMPERIAL)

### STEERABLE FRONT UNIT

Maximum Load	30 tons
Wheels (black)	24 @ 4 1/2" dia
Turntable Diameter	13 3/4"
Overall Loading Height	6 11/16"
Handle Length	69"

### ADJUSTABLE REAR UNITS

Maximum Load	30 tons
Wheels (black)	24 @ 4 1/2" dia
Load Area	2 @ 11 3/4" x 15 3/4"
Overall Loading Height	6 11/16"
Width Adjustment	31 1/2" - 78 3/4"

Total boxed weight of the Steerman S60 system is 666 lbs



## PRODUCT MATERIAL DATA

### Polyester Powder Coating

To provide a quality finish all painted components are finally prepared and polyester powder coat finished to meet the current European 'Qualicoat' Standards giving an average surface finish of between 70-80 microns. The coated components are baked to achieve a metal temperature of 180°C to ensure a properly stoved finish which gives a much more durable coating than wet paint systems.

### Axles and Pivot Pins

All finish machined axle shafts, handle pivot pins and wheel box pivot pins are bright zinc plated and completed with a clear passivated finish to prevent corrosion. With an average depth covering of between 15 to 20 microns this process ensures that the unit remains easily serviceable in extreme environmental conditions.

### Wheel Bearings

On all SX models 5 thru to 30 the wheels are fitted with single row deep groove ball bearings, shielded both sides to prevent ingress of debris and fitted with an extended outer race. The extended outer race gives low resistance when the wheels contra-rotate and provides a predetermined working clearance between each wheel. Due to the low ground speeds achieved with this type of equipment the radial loadings of the bearings increase accordingly. The bearing has sealed for life lubricant and is therefore unserviceable.

### Turntable Bearings

All models are fitted with single direction thrust ball bearings designed to accept high axial loadings, the three part bearing consists of 2 outer races with a central bearing race, the roller ball bearings are housed in a cage and the bearing can be cleaned and serviced when required. The cast nylon turntable absorbs a large percentage of any dynamic load placed on the turntable assembly, this can occur through natural means such as the movement of the skates with a load or the extreme case where a load is lowered by a crane onto the turntable (not recommended).

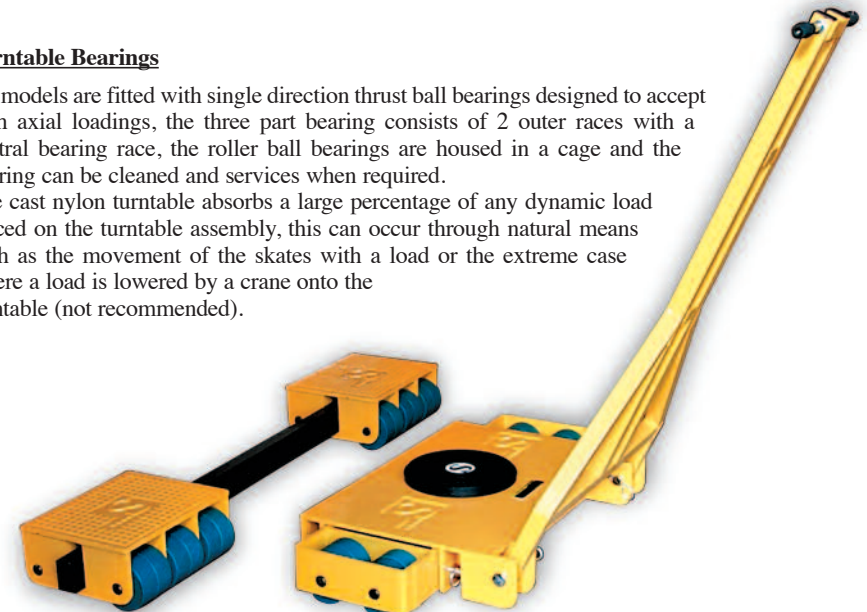

# MODEL SX5 - PARTS LIST

Item	Description	Part No.	Parts per system
1	Front Frame	S011001	1
2	Handle c/w Rubber Grips	S011002	1
3	Rear Trolley	S011019	2
4	Alignment Bar	S011004	1
5	Rubber Handle Grips	S011005	2
6	Wheel Assembly (Blue)	S011006	16
7	Turntable (Black)	S011007	1
8	Turntable Bolt	S011008	1
9	Turntable Bearing	S011009	1
10	"R" Clip (Handle Pin)	S011010	2
11	Axle Shaft (Rear)	S011011	4
12	Circlip	S011014	2
13	Axle Shaft (Front)	S011046	4
14	Anti-Slip Mat (Front)	S011015	1
15	Anti-Slip Mat (Rear)	S011016	2

\* Each Wheel Assembly comes complete with nylon wheel and two bearings fitted

## TECHNICAL DATA (METRIC)

### STEERABLE FRONT UNIT

Maximum Load	2.5 tonnes
Wheels (blue)	8 @ 82 mm dia
Turntable Diameter	162 mm
Overall Loading Height	102 mm
Handle Length	952 mm

### ADJUSTABLE REAR UNITS

Maximum Load	2.5 tonnes
Wheels (blue)	8 @ 82 mm dia
Load Area	2 @ 126 x 180 mm
Overall Loading Height	102 mm
Width Adjustment	252 - 1,200 mm

Total boxed weight of the Steerman SX5 system is 38 kgs

## TECHNICAL DATA (IMPERIAL)

### STEERABLE FRONT UNIT

Maximum Load	2 1/2 tons
Wheels (blue)	8 @ 3 1/4" dia
Turntable Diameter	6 1/4"
Overall Loading Height	4"
Handle Length	37"

### ADJUSTABLE REAR UNITS

Maximum Load	2 1/2 tons
Wheels (blue)	8 @ 3 1/4" dia
Load Area	2 @ 5" x 7"
Overall Loading Height	4"
Width Adjustment	10" - 47"

Total boxed weight of the Steerman SX5 system is 84 lbs

# MODEL S40 TOTAL SYSTEM CAPACITY 40 TONS

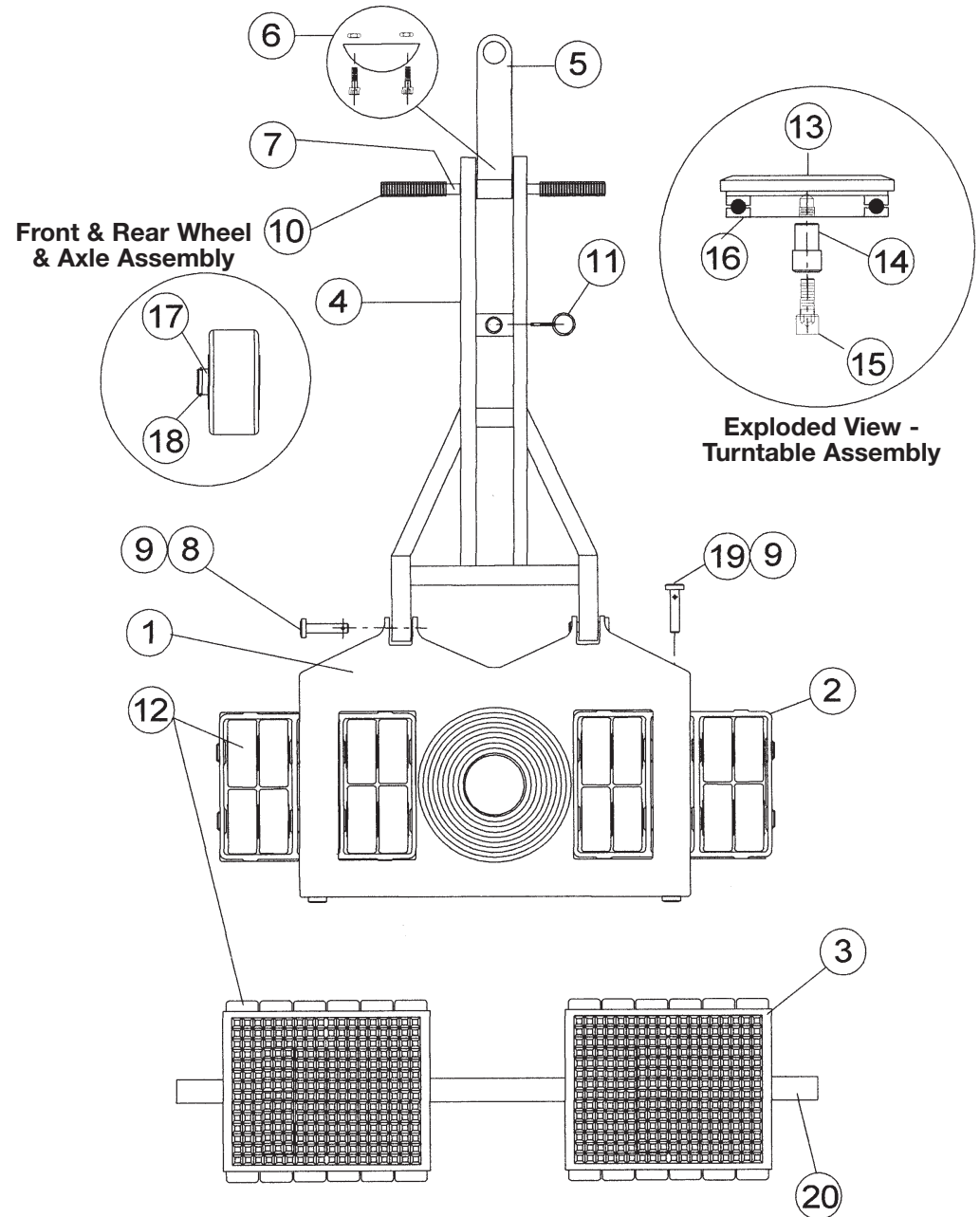



# MODEL S40 - PARTS LIST

Item	Description	Part No.	Parts per system
1	Front Frame	S011060	1
2	Front Wheel Box-Casting	S011061	2
3	Rear Trolley Casting	S011062	2
4	Handle	S011063	1
5	Tow Eye	S011064	1
6	Rubber Bump Stop	S011065	1
7	Pivot Shaft-Handle	S011066	1
8	Pivot Pin - Handle	S011067	2
9	"R" Clip - Pivot Pin (6mm)	S011068	6
10	Rubber Handle Grips	S011005	2
11	Lynch Pin - Tow Eye Retention	S011099	2
12	Wheel Assembly (Blue)	S011070	48
13	Turntable (Black)	S011071	1
14	Collar - Turntable Bolt	S011072	1
15	Turntable Bolt	S011072	1
16	Turntable Bearing	S011073	1
17	Axle Shaft (Front & Rear)	S011074	8
18	Circlip	S011075	16
19	Pivot Pin	S011076	4
20	Alignment Bar	S011077	1

\* Each Wheel Assembly comes complete with nylon wheel and two bearings fitted

## TECHNICAL DATA (METRIC)

### STEERABLE FRONT UNIT

Maximum Load	20 tonnes
Wheels (blue)	24 @ 115 mm dia
Turntable Diameter	350 mm
Overall Loading Height	170 mm
Handle Length	1,750 mm

### ADJUSTABLE REAR UNITS

Maximum Load	20 tonnes
Wheels (blue)	24 @ 115 mm dia
Load Area	2 @ 300 x 400 mm
Overall Loading Height	170 mm
Width Adjustment	800 - 2,000 mm

Total boxed weight of the Steerman S40 system is 302 kgs

## TECHNICAL DATA (IMPERIAL)

### STEERABLE FRONT UNIT

Maximum Load	20 tons
Wheels (blue)	24 @ 4 1/2" dia
Turntable Diameter	13 3/4"
Overall Loading Height	6 11/16"
Handle Length	69"

### ADJUSTABLE REAR UNITS

Maximum Load	20 tons
Wheels (blue)	24 @ 4 1/2" dia
Load Area	2 @ 11 3/4" x 15 3/4"
Overall Loading Height	6 11/16"
Width Adjustment	31 1/2" - 78 3/4"

Total boxed weight of the Steerman S40 system is 666 lbs

# MODEL SX5 TOTAL SYSTEM CAPACITY 5 TONS

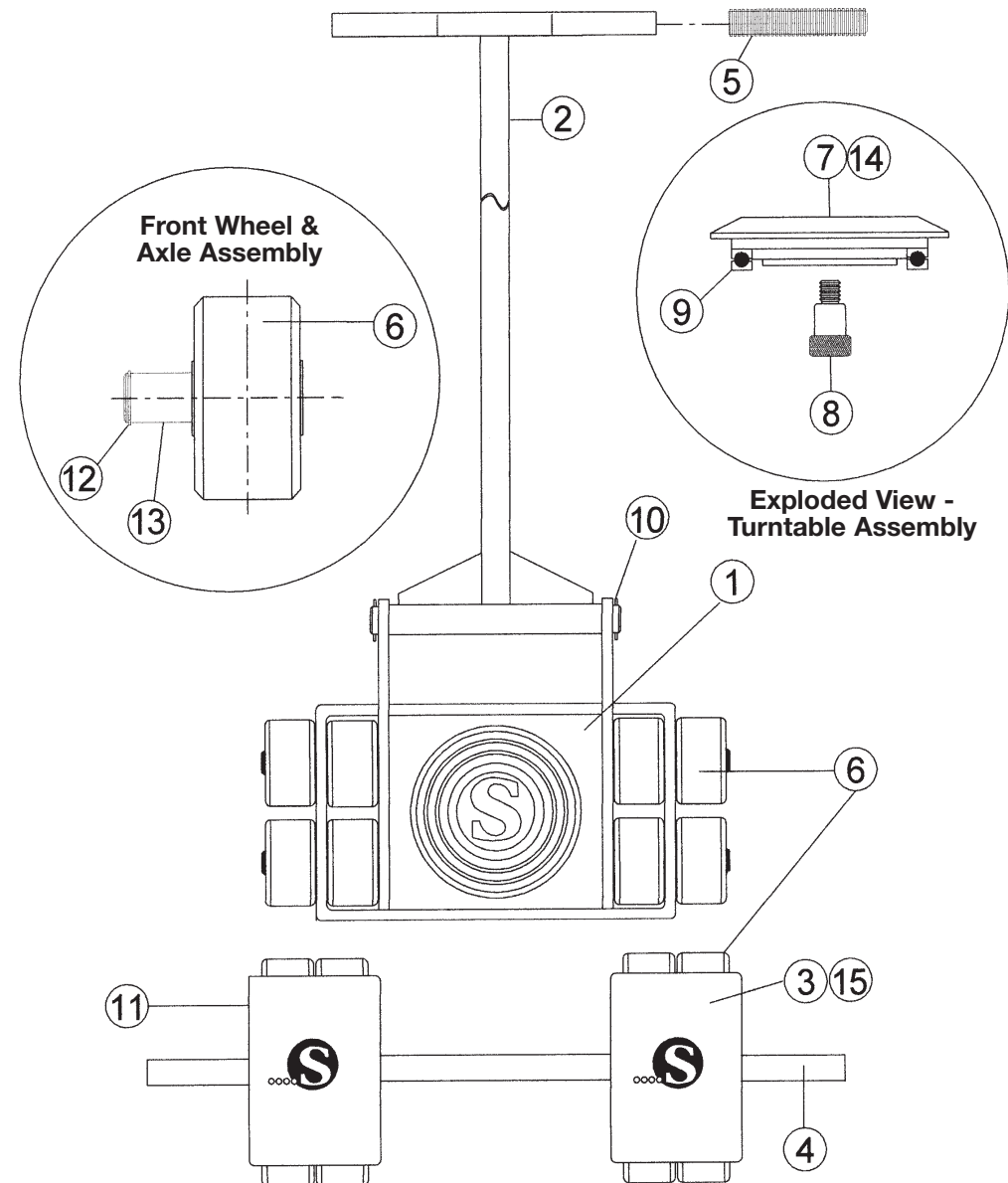

# MODEL SX10 - PARTS LIST

Item	Description	Part No.	Parts per system
1	Front Frame	S011017	1
2	Front Wheel Box-Casting	S011018	2
3	Rear Trolley Casting	S011019	2
4	Alignment Bar	S011004	1
5	Handle	S011020	1
6	Tow Eye	S011021	1
7	Foot Plate	S011022	1
8	Pivot Shaft-Handle	S011047	1
9	Anti-tip Roller	S011024	2
10	"R" Clip	S011010	6
11	Rubber Handle Grips	S011005	2
12	Bolt-Plated	S011025	2
13	Nut-Nyloc	S011026	2
14	Wheel Assembly (Black)	S011027	16
15	Turntable (Black)	S011028	1
16	Turntable Bolt	S011029	1
17	Turntable Bearing	S011030	1
18	Axle Shaft (Front & Rear)	S011011	8
19	Circlip	S011014	16
20	Pivot Pin	S011030A	4
21	Anti-Slip Mat (Front)	S011042	1
22	Anti-Slip Mat (Rear)	S011016	2

\* Each Wheel Assembly comes complete with nylon wheel and two bearings fitted

## TECHNICAL DATA (METRIC)

### STEERABLE FRONT UNIT

Maximum Load	5 tonnes
Wheels (black)	8 @ 82 mm dia
Turntable Diameter	180 mm
Overall Loading Height	102 mm
Handle Length	1,030 mm

### ADJUSTABLE REAR UNITS

Maximum Load	5 tonnes
Wheels (black)	8 @ 82 mm dia
Load Area	2 @ 126 x 180 mm
Overall Loading Height	102 mm
Width Adjustment	252 - 1,200 mm

Total boxed weight of the Steerman SX10 system is 54 kgs

## TECHNICAL DATA (IMPERIAL)

### STEERABLE FRONT UNIT

Maximum Load	5 tons
Wheels (black)	8 @ 3 1/4" dia
Turntable Diameter	7 1/16"
Overall Loading Height	4"
Handle Length	40"

### ADJUSTABLE REAR UNITS

Maximum Load	5 tons
Wheels (black)	8 @ 3 1/4" dia
Load Area	2 @ 5" x 7"
Overall Loading Height	4"
Width Adjustment	10" - 47"

Total boxed weight of the Steerman SX10 system is 119 lbs

# MODEL SX30 TOTAL SYSTEM CAPACITY 30 TONS

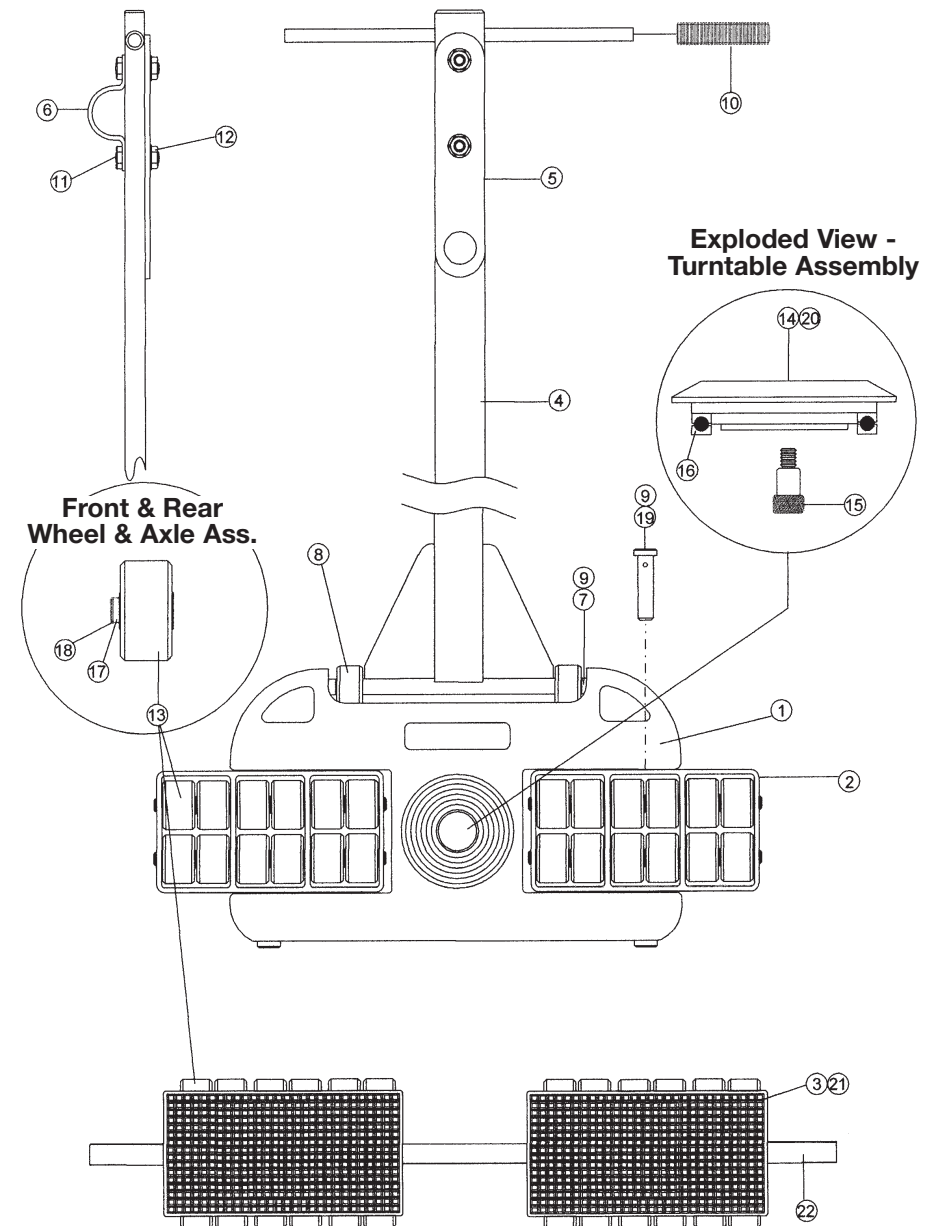

# MODEL SX30 - PARTS LIST

Item	Description	Part No.	Parts per system
1	Front Frame	S011036	1
2	Front Wheel Box-Casting	S011037	2
3	Rear Trolley Casting	S011038	2
4	Handle	S011039	1
5	Tow Eye	S011021	1
6	Foot Plate	S011022	1
7	Pivot Shaft-Handle	S011049	1
8	Anti-tip Roller	S011024	2
9	"R" Clip	S011010	6
10	Rubber Handle Grips	S011005	2
11	Bolt-Plated	S011025	2
12	Nut-Nyloc	S011026	2
13	Wheel Assembly (Black)	S011027	48
14	Turntable (Black)	S011028	1
15	Turntable Bolt	S011050	1
16	Turntable Bearing	S011030	1
17	Axle Shaft (Front & Rear)	S011040	8
18	Circlip	S011014	16
19	Pivot Pin	S011041	4
20	Anti-Slip Mat (Front)	S011042	1
21	Anti-Slip Mate (Rear)	S011043	2
22	Alignment Bar	S011045	1

\* Each Wheel Assembly comes complete with nylon wheel and two bearings fitted

## TECHNICAL DATA (METRIC)

### STEERABLE FRONT UNIT

Maximum Load	15 tonnes
Wheels (black)	24 @ 82 mm dia
Turntable	180 mm dia
Overall Loading Height	110 mm
Handle Length	1,550 mm

### ADJUSTABLE REAR UNITS

Maximum Load	15 tonnes
Wheels (black)	24 @ 82 mm dia
Load Area	2 @ 210 x 360 mm
Overall Loading Height	110 mm
Width Adjustment	720 - 1,500 mm

Total boxed weight of the Steerman SX30 system is 136 kgs

## TECHNICAL DATA (IMPERIAL)

### STEERABLE FRONT UNIT

Maximum Load	15 tons
Wheels (black)	24 @ 3 1/4 dia
Turntable	7 1/16" dia
Overall Loading Height	4 1/4"
Handle Length	63"

### ADJUSTABLE REAR UNITS

Maximum Load	15 tons
Wheels (black)	24 @ 3 1/4 dia
Load Area	2 @ 8 1/4" x 14 3/16"
Overall Loading Height	4 1/4"
Width Adjustment	28 1/4" - 59"

Total boxed weight of the Steerman SX30 system is 348 lbs

# MODEL SX10 TOTAL SYSTEM CAPACITY 10 TONS

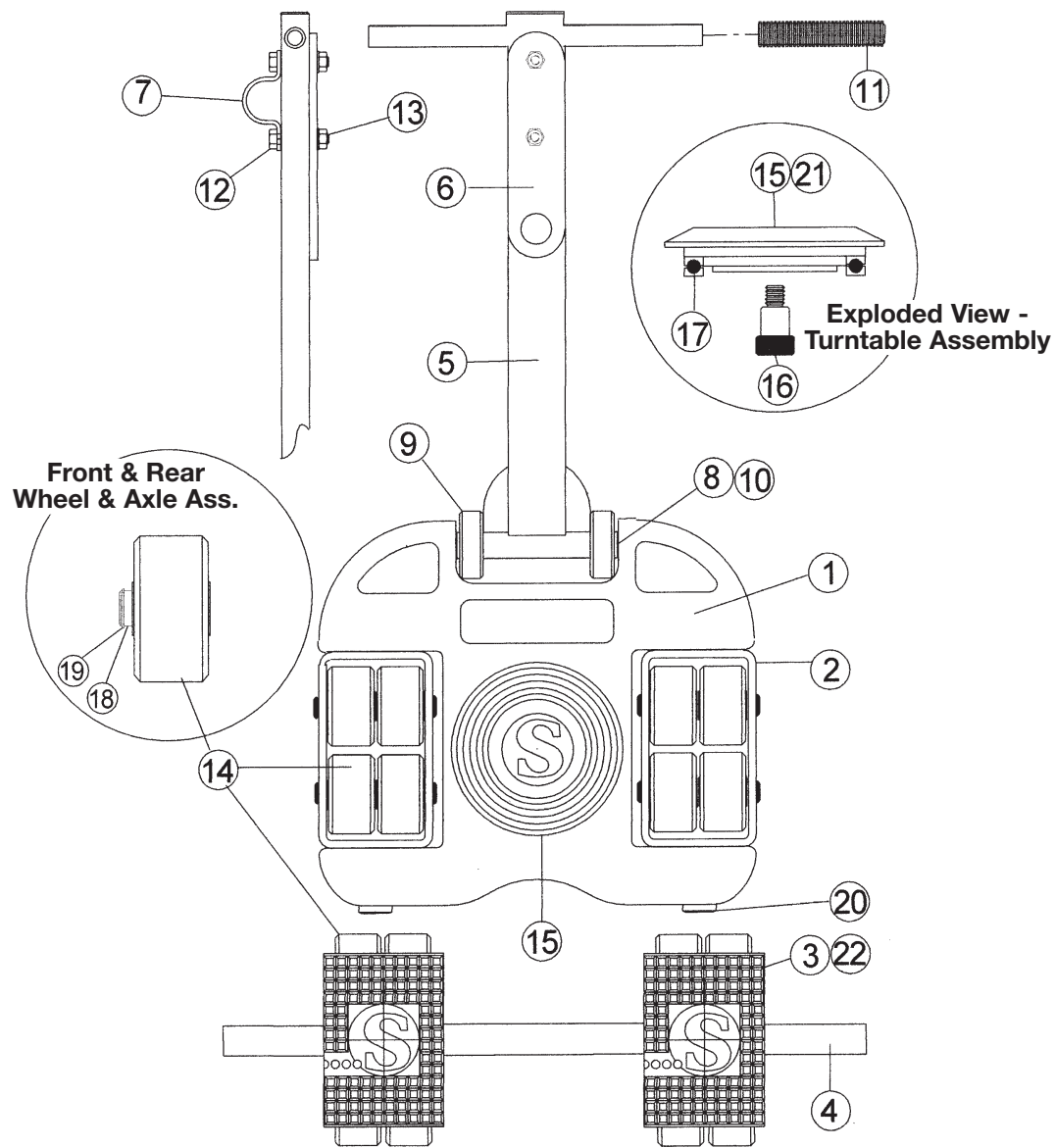

# MODEL SX15 - PARTS LIST

Item	Description	Part No.	Parts per system
1	Front Frame	S011031	1
2	Front Wheel Box-Casting	S011032	2
3	Rear Trolley-Casting	S011033	2
4	Handle	S011034	1
5	Tow Eye	S011021	1
6	Foot Plate	S011022	1
7	Pivot Shaft-Handle	S011048	1
8	Anti-tip Roller	S011024	2
9	"R" Clip	S011010	6
10	Rubber Handle Grips	S011005	2
11	Bolt-Plated	S011025	2
12	Nut-Nyloc	S011026	2
13	Wheel Assembly (Blue)	S011006	32
14	Turntable (Black)	S011028	1
15	Turntable Bolt	S011029	1
16	Turntable Bearing	S011030	1
17	Axle Shaft (Front & Rear)	S011035	8
18	Circlip	S011014	16
19	Pivot Pin	S011030A	4
20	Anti-Slip Mat (Front)	S011042	1
21	Anti-Slip Mate (Rear)	S011000	2
22	Alignment Bar	S011044	1

\* Each Wheel Assembly comes complete with nylon wheel and two bearings fitted

## TECHNICAL DATA (METRIC)

### STEERABLE FRONT UNIT

Maximum Load	7.5 tonnes
Wheels (blue)	16 @ 82 mm dia
Turntable Diameter	180 mm
Overall Loading Height	102 mm
Handle Length	1,310 mm

### ADJUSTABLE REAR UNITS

Maximum Load	7.5 tonnes
Wheels (blue)	16 @ 82 mm dia
Load Area	2 @ 176 x 240 mm
Overall Loading Height	102 mm
Width Adjustment	480 - 1,500 mm

Total boxed weight of the Steerman SX15 system is 76 kgs

## TECHNICAL DATA (IMPERIAL)

### STEERABLE FRONT UNIT

Maximum Load	7 1/2 tons
Wheels (blue)	16 @ 3 1/4" dia
Turntable Diameter	7 1/16"
Overall Loading Height	4"
Handle Length	51"

### ADJUSTABLE REAR UNITS

Maximum Load	7 1/2 tons
Wheels (blue)	16 @ 3 1/4" dia
Load Area	2 @ 6 3/4" x 9 1/4"
Overall Loading Height	4"
Width Adjustment	19"- 59"

Total boxed weight of the Steerman SX15 system is 168 lbs

# MODEL SX25 TOTAL SYSTEM CAPACITY 25 TONS

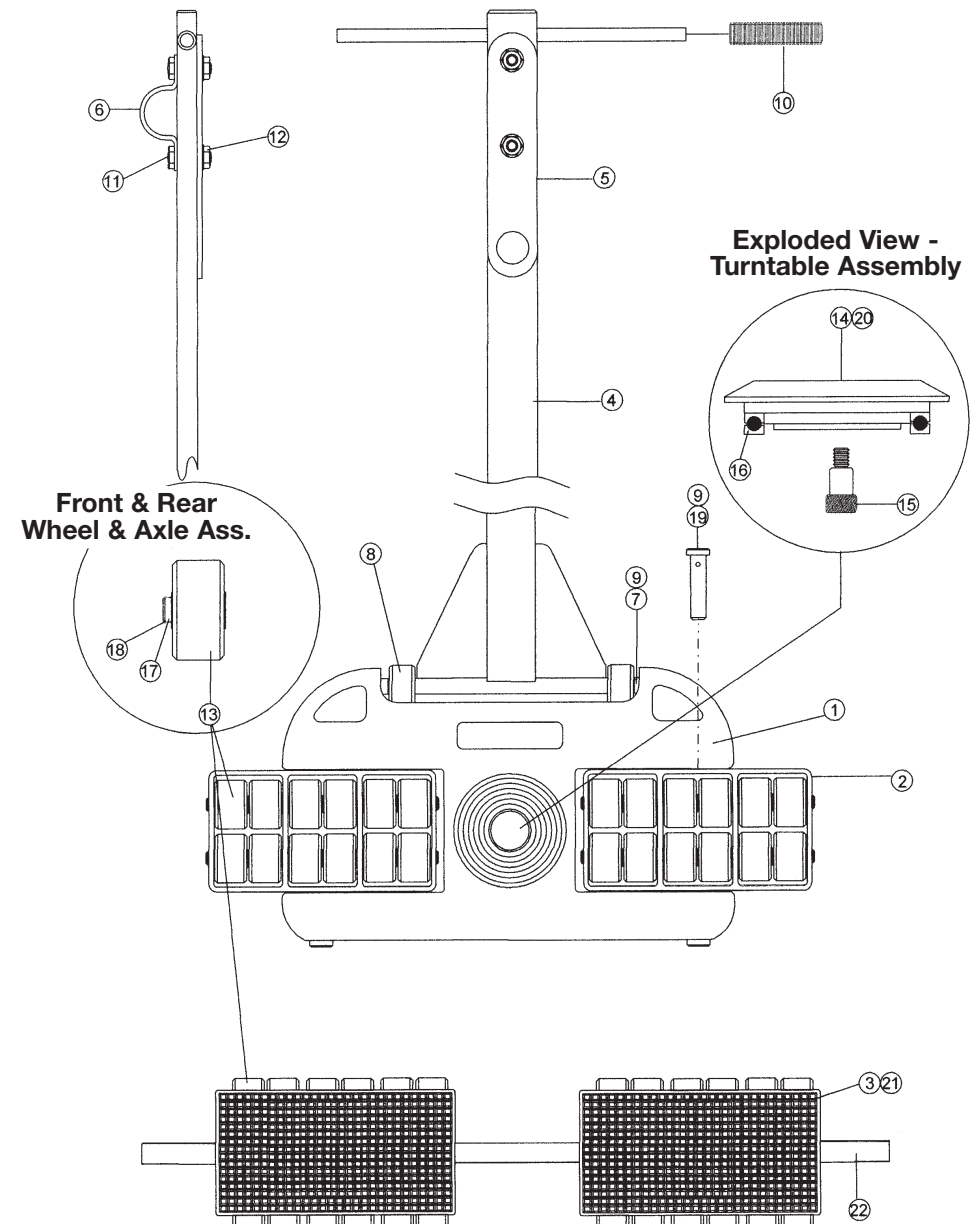

# MODEL SX25 - PARTS LIST

Item	Description	Part No.	Parts per system
1	Front Frame	S011036	1
2	Front Wheel Box-Casting	S011037	2
3	Rear Trolley Casting	S011038	2
4	Handle	S011039	1
5	Tow Eye	S011021	1
6	Foot Plate	S011022	1
7	Pivot Shaft-Handle	S011049	1
8	Anti-tip Roller	S011024	2
9	"R" Clip	S011010	6
10	Rubber Handle Grips	S011005	2
11	Bolt-Plated	S011025	2
12	Nut-Nyloc	S011026	2
13	Wheel Assembly (Blue)	S011006	48
14	Turntable (Black)	S011028	1
15	Turntable Bolt	S011050	1
16	Turntable Bearing	S011030	1
17	Axle Shaft (Front & Rear)	S011040	8
18	Circlip	S011014	16
19	Pivot Pin	S011041	4
20	Anti-Slip Mat (Front)	S011042	1
21	Anti-Slip Mat (Rear)	S011043	2
22	Alignment Bar	S011045	1

\* Each Wheel Assembly comes complete with nylon wheel and two bearings fitted

## TECHNICAL DATA (METRIC)

### STEERABLE FRONT UNIT

Maximum Load	12.5 tonnes
Wheels (blue)	24 @ 82 mm dia
Turntable Diameter	180 mm
Overall Loading Height	110 mm
Handle Length	1,550 mm

### ADJUSTABLE REAR UNITS

Maximum Load	12.5 tonnes
Wheels (blue)	24 @ 82 mm dia
Load Area	2 @ 210 x 360 mm
Overall Loading Height	110 mm
Width Adjustment	720 - 1,500 mm

Total boxed weight of the Steerman SX25 system is 136 kgs

## TECHNICAL DATA (IMPERIAL)

### STEERABLE FRONT UNIT

Maximum Load	12 1/2 tons
Wheels (blue)	24 @ 3 1/4" dia
Turntable diameter	7 1/16"
Overall Loading Height	4 1/4"
Handle Length	61"

### ADJUSTABLE REAR UNITS

Maximum Load	12 1/2 tons
Wheels (blue)	24 @ 3 1/4" dia
Load Area	2 @ 6 3/4" x 14 3/16"
Overall Loading Height	4"
Width Adjustment	28 1/4" - 59"

Total boxed weight of the Steerman SX25 system is 300 lbs

# MODEL SX15 TOTAL SYSTEM CAPACITY 15 TONS

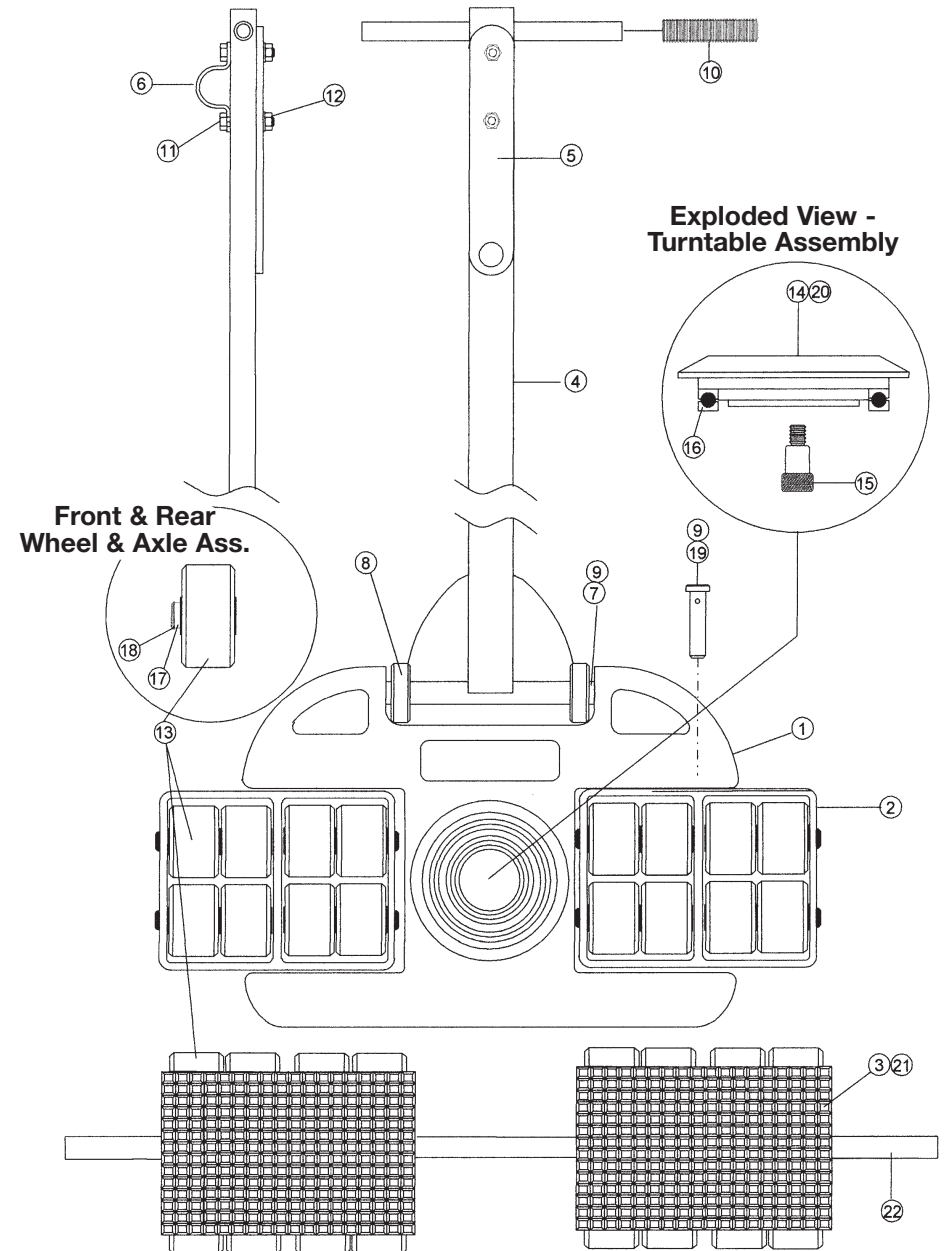

# MODEL SX20 - PARTS LIST

Item	Description	Part No.	Parts per system
1	Front Frame	S011031	1
2	Front Wheel Box-Casting	S011032	2
3	Rear Trolley-Casting	S011033	2
4	Handle	S011034	1
5	Tow Eye	S011021	1
6	Foot Plate	S011022	1
7	Pivot Shaft-Handle	S011048	1
8	Anti-tip Roller	S011024	2
9	"R" Clip	S011010	6
10	Rubber Handle Grips	S011005	2
11	Bolt-Plated	S011025	2
12	Nut-Nyloc	S011026	2
13	Wheel Assembly (Black)	S011027	32
14	Turntable (Black)	S011028	1
15	Turntable Bolt	S011029	1
16	Turntable Bearing	S011030	1
17	Axle Shaft (Front & Rear)	S011035	8
18	Circlip	S011014	16
19	Pivot Pin	S011030A	4
20	Anti-Slip Mat (Front)	S011042	1
21	Anti-Slip Mat (Rear)	S011000	2
22	Alignment Bar	S011044	1

\* Each Wheel Assembly comes complete with nylon wheel and two bearings fitted

## TECHNICAL DATA (METRIC)

### STEERABLE FRONT UNIT

Maximum Load	10 tonnes
Wheels (black)	16 @ 82 mm dia
Turntable Diameter	180 mm
Overall Loading Height	102 mm
Handle Length	1,310 mm

### ADJUSTABLE REAR UNITS

Maximum Load	10 tonnes
Wheels (black)	16 @ 82 mm dia
Load Area	2 @ 176 x 240 mm
Overall Loading Height	102 mm
Width Adjustment	480 - 1,500 mm

Total boxed weight of the Steerman SX20 system is 76 kgs

## TECHNICAL DATA (IMPERIAL)

### STEERABLE FRONT UNIT

Maximum Load	10 tons
Wheels (black)	16 @ 3 1/4" dia
Turntable Diameter	7 1/16" dia
Overall Loading Height	4"
Handle Length	51"

### ADJUSTABLE REAR UNITS

Maximum Load	10 tons
Wheels (black)	16 @ 3 1/4" dia
Load Area	2 @ 6 3/4" x 9 1/4"
Overall Loading Height	4"
Width Adjustment	19" - 59"

Total boxed weight of the Steerman SX20 system is 168 lbs

# MODEL SX20 TOTAL SYSTEM CAPACITY 20 TONS

