

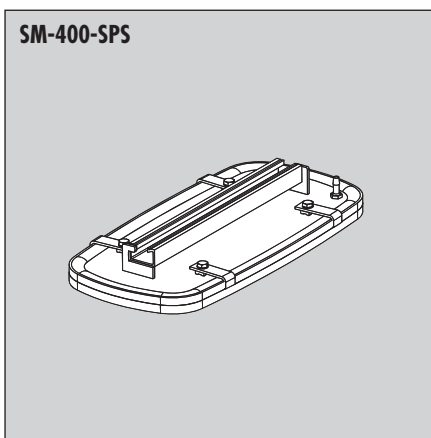

SM-400

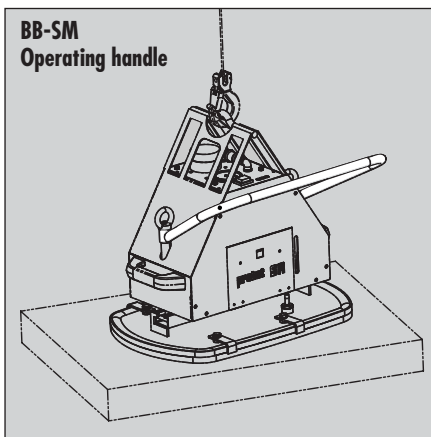

SM-400-SPS



BB-SM
Operating handle

STONEMAGNET SM-400 Vacuum Lifting Device

Handy, powerful and cordless vacuum lifting device for laying of dense stone slabs, concrete elements, pipes and similar. Can be used on all kind of lifting equipment.

- ▶ Specially designed and equipped for heavy duty work on the construction site.
- ▶ For special purposes, there are different suction plates available, which can be attached to the SM easily.

Standard Specifications:

- ▶ Robust and compact main body, with integrated suspension for crane hook and quick change device for the suction plate.
- ▶ Powered by rechargeable, exchangeable 12 V battery. Power saving control system makes battery lasting for one whole working day. Battery can be exchanged within seconds. Battery charge indicator.

▶ Security features: Flashing light to warn on insufficient low pressure, automatic control system to start the vacuum pump after loss of pressure, manometer, high volume vacuum storage tank.

▶ Standard suction plate 580 x 280 mm with special seal system, exchangeable within seconds without the use of glue or tools. No damage to the seal when setting on sharp edges for long time (no "supports" necessary).

Special features:

The SM is equipped with 2 vacuum-pumps as standard. When handling dense products, only one pump is used. On slightly porous material, or when quick cycle time is required, the second pump can be switched on by the TURBO switch.

STONEMAGNET SM-400 Vacuum Lifting Device

- basic unit -

Type	Drive	Dead Weight kg (lbs)		Order-Number
SM [Ⓞ]	by 12 V battery	35 (78)	without suction plate	5272.0002

Accessories

Type	Description	Order-Number
SM-SPS-90 [Ⓞ]	Suction plate, carrying approx. 90 kg* (200 lbs)* Dimensions approx. 300 x 200 mm (11 ³ / ₄ " x 7 ³ / ₄ "	4272.0009
SM-SPS-200 [Ⓞ]	Suction plate, carrying approx. 200 kg* (440 lbs)* Dimensions approx. 580 x 280 mm (22 ³ / ₄ " x 11")	4272.0001
SM-SPS-400 [Ⓞ] (for heavy loads)	Suction plate, carrying approx. 400 kg* (880 lbs)* Dimensions approx. 750 x 260 mm (29 ¹ / ₂ " x 10 ¹ / ₄ "	4272.0002
Battery	Spare storage battery, 24 Ah, 12 V	2420.0008
LG Battery charging device 220 V / 12 V	Battery charging device w/overload protection and charging current limiting. Housing is water and dust-proof.	2420.0016
SM-BB Operating handle [Ⓞ]	(also for retrofitting)	4272.0063
SM-ED-SPS-90	Highly wear-resistant replacement seal: Easy to attach without glueing.	4250.0023
SM-ED-SPS-200		4272.0004
SM-ED-SPS-400		4272.0005

Special suction plates, for example for pipes, on request.

* Value at 500 mbar low pressure

Ⓞ Durable surface protection by galvanizing