

## Hand pallet truck model HU 26-115 TMt PROLINE MOTION

Capacity 2600 kg

For the professional transportation of palletised goods and box pallets under demanding conditions.

### Features

- Ergonomic safety control handle for one-hand operation of lifting, driving and lowering.
- Ergonomic designed control handle for safe handling.
- Low maintenance high performance hydraulic pump with hard chromium plated piston and pressure relief valve.
- Frame and forks in robust steel construction, adjustable connecting rods, especially hardened axles and the high quality powder coating ensure a long life expectancy.
- Apron with shock absorbing rubber buffer in Pfaff-design.
- Steering angle of 105 degree to each side for easy handling in confined spaces.
- Entry rollers facilitate entry into bottom boarded pallets.



Option: Parking brake



### Technical data model HU 26-115 TMt PROLINE MOTION

Model	HU 26-115 TMt	HU 26-115 TMt
Art.-No.	040009215	040009873
Capacity, kg	2600	2600
Load center c, mm	600	600
Weight, kg	86	86
Tyre type*	VG/PUR	PUR/PUR
Steering rollers, mm	200x50	200x50
Load rollers, mm	84x70	84x70
Number of wheels/load rollers	2/4	2/4
Stroke h3, mm	115	115
Height of control handle h14, mm	1200	1200
Fork height lowered h13, mm	85	85
Overall length L1, mm	1535	1535
Fork height s, mm	45	45
Fork width e, mm	160	160
Fork length l, mm	1150	1150
Outside dimension of forks b1, mm	540	540
Inside dimension of forks b3, mm	220	220
Ground clearance m1, mm	40	40
Aisle width pallet Ast, mm	1815	1815
Turning circle radius Wa, mm	1330	1330

\*PUR... Polyurethane, VG... Solid rubber

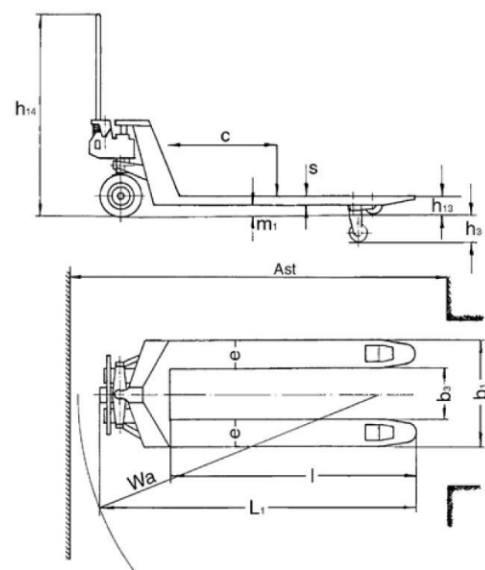

Hand pallet truck model HU 26-115 TMt PROLINE MOTION  
Hand pallet truck model HU 25-115 TS and ES SILVERLINE