

Lebus® Load Binders



Load Rated



SEE APPLICATION AND WARNING INFORMATION

Para Español: www.thecrosbygroup.com

On Page 246

A-1W



- Forged steel – Quenched and Tempered.
- Used as a come-a-long for short take-up on chain.
- Binder toggles away from the load.

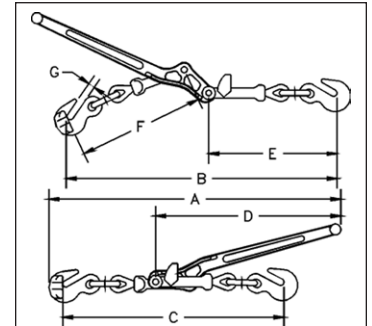

A-1W Walking Load Binders

- Meets or exceeds requirements of US DOT FMCSA Part 393 Subpart I.

Model	Stock No.	Chain Size (mm)	Working Load Limit (t)	Proof Load (kN)	Ultimate Load (t)	Weight Each (kg)	Handle Length (mm)	Dimensions (mm)						
								A	B	C	D	E	F	G
A-1W	1048388	13 only	4.17	82	15.0	5.94	475	730	654	540	475	313	314	16.0

R-10

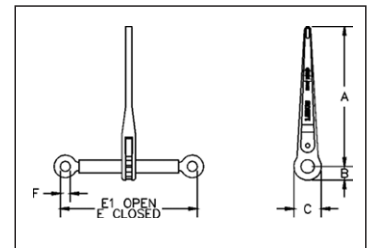

R-10 Binder without Links and Hooks

- Meets or exceeds requirements of US DOT FMCSA Part 393 Subpart I.

Model	Stock No.	Working Load Limit (t)*	Weight Each (kg)	Handle Length (mm)	Barrel Length (mm)	Take Up (mm)	Dimensions (mm)					
							A	B	C	E	E1	F
R-10	1048468	7.26	3.65	356	254	203	356	35.1	70.0	356	559	25.4

* Ultimate Load is 3 times the Working Load Limit.

Chain & Accessories