

# Crosby® Alloy Screw Pin Shackles

**Load Rated®**



## G-209A



G-209A Screw pin anchor shackles meet the performance requirements of Federal Specification RR-C-271E Type IVA, Grade B, Class 2, except for those provisions required of the contractor. For additional information, see page 450.

- Capacities 2 thru 21 metric tons.
- Forged Alloy Steel – Quenched and Tempered, with alloy pins.
- Working Load Limit permanently shown on every shackle.
- Hot Dip Galvanized.
- Shackles can be furnished proof tested with certificates to designated standards, such as ABS, DNV, Lloyds, or other certification. Charges for proof testing and certification available when requested at the time of order.
- Meets or exceeds all requirements of ASME B30.26 including identification, ductility, design factor, proof load and temperature requirements. Importantly, these shackles meet other critical performance requirements including fatigue life, impact properties and material traceability, not addressed by ASME B30.26.

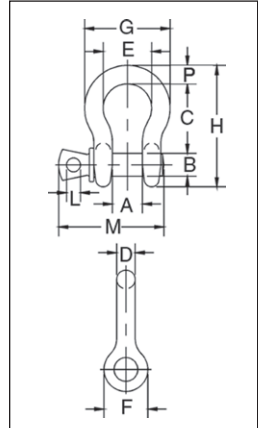

## G-209A Crosby® Alloy Screw Pin Shackles

Nominal Size (in.)	Working Load Limit (t)*	G-209A Stock No.	Weight Each (kg)	Dimensions (mm)											Tolerance +/-	
				A	B	C	D	E	F	G	H	L	M	P	C	A
3/8	2	1017450	.14	16.8	11.2	36.6	9.65	26.2	23.1	45.2	63.5	6.35	51.5	9.65	3.30	1.50
7/16	2-2/3	1017472	.17	19.1	12.7	42.9	11.2	29.5	26.9	51.5	74.0	7.85	60.5	11.2	3.30	1.50
1/2	3-1/3	1017494	.29	20.6	16.0	47.8	12.7	23.3	30.2	58.5	83.5	9.65	68.5	12.7	3.30	1.50
5/8	5	1017516	.63	26.9	19.1	60.5	16.0	42.9	38.1	74.5	106	11.2	85.0	17.5	3.30	1.50
3/4	7	1017538	1.02	31.8	22.4	71.5	19.1	51.0	46.0	89.0	126	12.7	101	20.6	6.35	1.50
7/8	9-1/2	1017560	1.53	36.6	25.4	84.0	22.4	58.0	53.0	102	148	12.7	114	24.6	6.35	1.50
1	12-1/2	1017582	2.41	42.9	28.7	95.5	25.4	68.5	60.5	119	167	14.2	129	26.9	6.35	1.50
1-1/8	15	1017604	3.09	46.0	31.8	108	29.5	74.0	68.5	131	190	16.0	142	31.8	6.35	1.50
1-1/4	18	1017626	4.31	51.5	35.1	119	32.8	82.5	76.0	146	210	17.5	156	35.1	6.35	1.50
1-3/8	21	1017648	6.01	57.0	38.1	133	36.1	92.0	84.0	162	233	19.1	174	38.1	6.35	3.30

\* Maximum Proof Load is 2 times the Working Load Limit (metric tons). Minimum Ultimate Load is 4.5 times the Working Load Limit based on metric tons. For Working Load Limit reduction due to side loading applications, see page 80.

**Load Rated®**



## G-2169



## S-2169



- Capacities of 7, 12.5 and 18 metric tons.
- Quenched and Tempered for maximum strength.
- Forged Alloy Steel.
- Available in galvanized and self colored finished.
- Individually proof tested and magnetic particle inspected. Crosby certification available at time of order.
- Meets or exceeds all requirements of ASME B30.26 including identification, ductility, design factor, proof load and temperature requirements. Importantly, these shackles meet other critical performance requirements including fatigue life, impact properties and material traceability, not addressed by ASME B30.26.
- Look for the Red Pin® . . . the mark of genuine Crosby quality.

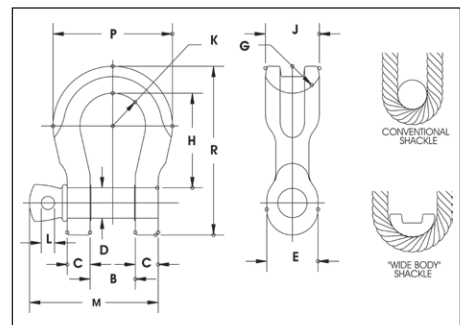

## G-2169 / S-2169 Screw Pin "Wide Body" Shackles

Working Load Limit (t)*	G-2169 Stock No.	S-2169 Stock No.	Weight Each (kg)	Dimensions (mm)												
				B +/- .25	C	D +/- .02	E	G	H	J	K	L	M	P	R	
7	1021655	1021664	7.7	31.8	17.5	22.4	46.2	31.8	90.4	40.6	31.8	12.7	101	104	149	
12.5	1021673	1021682	19.4	42.9	23.4	28.7	60.5	34.8	118	54.1	41.4	14.2	130	140	194	
18	1021691	1021699	28.7	51.6	29.5	35.1	68.3	38.1	148	63.5	50.8	17.5	159	172	238	

\* Ultimate Load is 5 times the Working Load Limit. Forged Alloy Steel. Proof Load is 2 times the Working Load Limit.